

arcaplex|Horizon



ISDN MULTIPLEXER

arcatech Ltd

Unit 210-212 LEO
Lisburn, BT28 2BP
Northern Ireland

T: +44 (0) 28 926 77204

E: tech@arcatech.com

W: www.arcatech.com

Revision: 1.7c

Document released: 1st July 2006

TABLE OF CONTENTS

	Introduction	5
	Product Specification	7
	Quick Reference Guide	9
CHAPTER 1	Installation	15
CHAPTER 2	Menu System	17
CHAPTER 3	Protocol Analyser	44
CHAPTER 4	Command Line Interface	54
CHAPTER 5	Fault Finding	146
APPENDICES	Reprogramming the FLASH	152
	Reprogramming an analogue card	158
	Default settings	163
	Pin-outs	167
	BRI power feeding	171
	Examples of number setup (ETSI protocol)	173
	Examples of number setup (National ISDN protocol)	179
	SNMP support	181
	Glossary	183

INTRODUCTION

arcaplex|Horizon allows analogue and basic rate ISDN terminals to be used with a primary rate ISDN connection. A primary rate terminal ISDN can also be connected.

Basic rate interfaces (BRI) and analogue (PSTN) interfaces are provided by line cards. Up to 2 line cards can be fitted.

There are 2 BRI line cards – a card with 8 S_0 interfaces (I.430 compatible) and a card with 8 U interfaces (ANSI T1.601 compatible).

The analogue card has 16 analogue interfaces.

The Primary rate interfaces (PRI) can be configured as S_{2m} interfaces (i.e. E.1 G.703 compatible) or T.1 interfaces.

The manual This manual outlines how **arcaplex|Horizon** should be set up and how the network and terminal equipment is connected.

PRODUCT SPECIFICATION

ISDN Connections **arcaplex|Horizon** connects to the network via an ISDN S_{2m} or T.1 PRI interface acting as a terminal.

arcaplex|Horizon provides up to sixteen BRI's via line cards with 8 S₀ or 8 U ports and one ISDN S_{2m} or T.1 PRI port operating in NT mode. The BRI interfaces can optionally provide power feeding (40V, 1W for S₀; 88V, 3W for U).

LED's indicate the operating level of each port. (1) P led to indicate physical layer and data link layer activated, (2) B led to indicate that at least one B channel is active.

Analogue (PSTN) Connections **arcaplex|Horizon** provides up to 32 analogue lines via line cards with 16 analogue lines.

The analogue lines feature -48V feed and ringing. Tone (DTMF) and pulse dialing are supported. FSK (ETSI), FSK (Bellcore) and DTMF caller ID signalling are provided.

An LED at each port indicates off-hook and ringing.

Terminal Port A V.24 port is provided allowing the connection of an ANSI (or Wyse 50) compatible terminal or PC for setting up the unit.

Ethernet Port An IEEE 802.3 ethernet port is provided for connection to a local area network.

LED's indicate (1) network present, (2) network activity.

Modem Port An optional modem port is provided to allow **arcaplex|Horizon** to be controlled remotely.

LED's indicate that the modem is (1) off hook / ringing, (2) connected.

PRODUCT SPECIFICATION

Power **arcaplex|Horizon** is available in mains powered and dc powered versions. The mains version accepts a voltage of 110-240V a.c (50-60Hz). The dc version accepts a voltage of -36V to -72V d.c. Maximum power consumption is 90W.

Mechanical **arcaplex|Horizon** is enclosed in a 2U high 19" rack case. Dimensions are approximately 9cm high x 49cm wide x 40cm deep. Weight is approximately 5Kg.

QUICK REFERENCE GUIDE

Introduction **arcaplex|Horizon** consists of a chassis, mains or dc power supply, controller card and up to 2 line cards. The controller card must be fitted in the first slot.

There are no user serviceable parts inside **arcaplex|Horizon**. It should only be opened by approved maintenance staff, otherwise the warranty will be invalidated.



Figure 1 **arcaplex|Horizon** front and rear panels

Chassis The chassis consists of a metal case and a backplane to accept the

QUICK REFERENCE GUIDE

controller card, line cards and power supply.

Mains Power supply

The mains power supply has a universal input suitable for 110V-240Vac/50-60Hz. Connection to any other source may result in the unit failing to comply with safety requirements.

Power should be supplied via an IEC mains lead (supplied).

The power supply must have a protective ground (earth). If not the mains filter will force the metal case to a voltage equal to half the mains supply voltage.

DC power supply

The dc power supply has 2 input connectors. Both accept a voltage of $-36V$ to $-72V$. Power can be connected to either or both input connectors.

NB the 0V connections on both connectors are common and are connected to the case.

The 0V connection should be connected to earth.



Figure 2 arcaplex|Horizon controller card

QUICK REFERENCE GUIDE

Controller card

The controller card features 2 primary rate ports, 2 PC Card slots (not used), modem (optional), LAN port, terminal port and LED's.

The terminal port is a V.24 compatible control port to which a PC or VT100 compatible terminal or a PC emulating an ANSI terminal (e.g. running Procom, Windows Terminal, Hyper terminal etc.) can be connected.

The LAN port is an IEEE 802.3 compatible Ethernet port. It allows **arcaplex|Horizon** to be controlled remotely via Telnet. Software upgrades are possible via FTP. SNMP is also supported (see [appendix](#)). If SNMP is to be used contact **arcatech** for the MIB file.

The Line port is the modem (optional) which connects to an analogue telephone line.

Port 1 and port 2 are the primary rate ports - PRI 1 and PRI 2. PRI 1 provides the PRI connection to a PRI line. PRI 2 provides the PRI connection to a PRI terminal equipment.

Pin-outs of the terminal, ethernet, modem and PRI ports are given in an [appendix](#).

LED's indicate power and alarm.

For each primary rate port the P LED is on when both physical link layer and data link layer are active. It flashes when only the physical link is active. The B LED is on when any B channel is in use.

For the Ethernet port the P LED indicates network present and the B LED indicates network activity.

For the modem port the P LED is on for off-hook and flashing for

QUICK REFERENCE GUIDE

ringing. The B LED indicates modem connected.

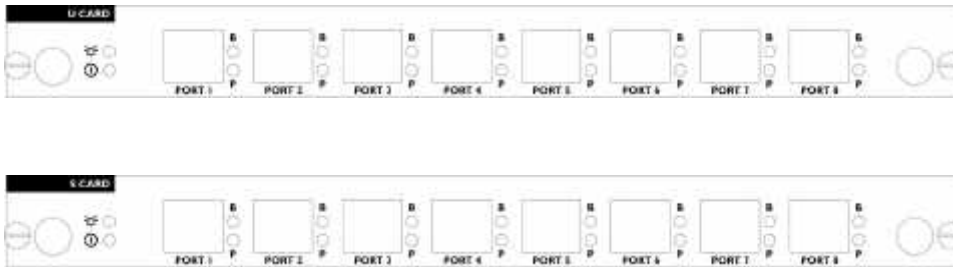

Figure 3 arcaplex|Horizon U card and S card

U and S cards

The U and S cards feature 8 Basic Rate Ports and LED's.

Ports 1-8 are BRI 1-8 if fitted in the first line card slot or BRI 9-16 if fitted in the second line card slot.

Pin-outs of the BRI interfaces are given in an [appendix](#).

LED's indicate power and alarm.

For each port the P LED is on when both physical link layer and data link layer are active. It flashes when only the physical link is active. The B LED is on when any B channel is in use.

The P and B LED's flash alternately if the power is cut off due to an overload condition.



Figure 4 arcaplex|Horizon A card

QUICK REFERENCE GUIDE

A card The A card features 16 analogue (PSTN) ports and LED's.

Ports 1-16 are A1-16 if fitted in the first line card slot or A17-32 if fitted in the second line card slot.

Pin-outs of the analogue interfaces are given in an [appendix](#).

For each port the LED is on when a phone is connected and off-hook. The LED flashes to indicate ringing.

Restoring default settings

When the unit is first switched on the terminal port will default to 19200 baud, no parity, 8 data bits and 2 stop bits and will search for a <ctrl-c> being transmitted to **arcaplex|Horizon**. If this occurs **arcaplex|Horizon** will restore the factory defaults otherwise it will use the stored settings.

If a setting has been changed and **arcaplex|Horizon** ceases to operate, powering up **arcaplex|Horizon**, while holding down <ctrl-c> for the first 20 seconds will restore a working configuration to **arcaplex|Horizon**.

The default settings are listed in an [appendix](#).

QUICK REFERENCE GUIDE

INSTALLATION

Unpack arcplex Horizon	First unpack arcplex Horizon and check for signs of damage in transit. If the unit or packaging is damaged this should be reported immediately to arcatech .
Take an Inventory	<p>Assuming there is no damage, take an inventory of the parts supplied. Check that the items ordered were actually received. The list below should be of help in identifying each part.</p> <ul style="list-style-type: none">◆ arcplex Horizon ISDN Multiplexer◆ Cables for ISDN - RJ45-RJ45 (2 off)◆ Mains Cable◆ Terminal Cable DB9-DB9 (1 off)◆ This Manual
Connect to a PC or terminal	<p>Plug the terminal cable into the rear of the unit and connect to a terminal or PC.</p> <p>(arcplex Horizon default terminal settings are ANSI terminal compatible, 19200 baud, 8 data bits, no parity, 2 stop bits).</p>
Connect power	<p>Plug the power cable into the rear of the unit and switch on</p> <p>(arcplex Horizon will work on 110V or 240V mains supply without adjustment).</p>
Configure arcplex Horizon	Set up arcplex Horizon using the menus (see chapter 2 - Menu System).
Connect PRI line	Plug an ISDN cable into PRI 1 (port 1 on controller card) and connect it to the network provided PRI line.
Connect terminal equipment	<p>Plug a basic rate terminal into an enabled BRI, an analogue telephone into an enabled analogue line or a primary rate terminal into PRI2 (if enabled).</p> <p>Make sure that the equipment is compatible with the interface it is connected to.</p>

CHAPTER 1

INSTALLATION

NB in the UK master sockets should be connected between the analogue connections (RJ11) and telephones.

Make calls Try making calls from the enabled ports e.g. call the speaking clock.

MENU SYSTEM

Introduction This chapter outlines the user interface of **arcaplex|Horizon** and how the various functions of **arcaplex|Horizon** are set up and used.

arcaplex|Horizon has 2 user interfaces - command line interface and menu system. The menu system is described here. Details of the command line interface are provided in chapter 4 - [Command Line Interface](#).

The user interfaces operate in 2 modes - user and super. User mode only allows read access to configuration. Super mode allows read and write access. There is a facility to protect access to super mode with a password.

Power Up Screen Assuming that the hardware has been set up as described in chapter 1 – [Installation](#), when power is applied the following message should be displayed on the user terminal or PC

```
Copyright Digital Engineering 1999
ISDN Multiplexer V1.3e 16 November 1999

User Mode    - Type 'super' <RETURN> for write access
Command Mode - Type 'menu' <RETURN> to use menus

mux [U]>
```

Figure 5 **arcaplex|Horizon** power up display

The default data format is 19200 baud, 8 data bits, 2 stop bits, no parity. If no message appears then there is probably something wrong with the control cable. If some characters are displayed but the format is strange then the terminal parameters are probably incorrect. Try adjusting the terminal parameters so that they match **arcaplex|Horizon**.

CHAPTER 2

MENU SYSTEM

arcaplex|Horizon starts with the command line interface and user mode. Type 'super' <RETURN> to change to supervisor mode. Type 'menu' <RETURN> to change to the menu system.

Copyright Screen

When the menu system is first selected the Copyright Screen is displayed. It can be displayed again by pressing <ESCAPE> from the main menu.

To return to the command line interface press <ESCAPE> from the Copyright Screen.

```
Copyright Digital Engineering 1999
ISDN Multiplexer V1.3e 16 November 1999
```

```
BRI 9 0  BRI10 0  BRI11 0  BRI12 0  BRI13 0  BRI14 0  BRI15 0  BRI16 0
BRI 1 0  BRI 2 0  BRI 3 0  BRI 4 0  BRI 5 0  BRI 6 0  BRI 7 0  BRI 8 0
                                PRI 1 0  PRI 2 0
```

Figure 6 **arcaplex|Horizon** copyright screen

Nothing further will happen until you press a key. Note that once the unit has been set up by the user it is not necessary to set it up each time it is powered on, and consequently the terminal need not be connected thereafter.

Status Information

Further status information can be switched on and off by pressing 's'. B channels are marked /, -, #, r meaning disabled, not in use, in use, requested respectively.

Main Menu

Press 'Enter' to display the main set up screen, shown in figure 7.

```
System Setup
Hardware Setup
Software Setup
```

MENU SYSTEM

Analyser Setup

Figure 7 Main System Menu

Changing Parameters

The setup of **arcaplex|Horizon** is structured like a tree with the menu of figure 7 at the top. The user moves to a more detailed lower function by using the <up-arrow> and <down-arrow> keys to select the desired function and presses <enter> on the keyboard. To move to the next higher function press the <esc> key on the keyboard. Note that <u> and <d> perform the same function as <up-arrow> and <down-arrow>.

The <home> and <end> keys can be used to move the cursor to the first and last item in the menu if the terminal program supports them.

If there is more than 1 column of items in the menu to move across the menu. <left-arrow> and <right-arrow> can also be used to display the menu for the previous and next ports in the Number Setup menu's for individual BRI's and analogue interfaces.

Once you have located the item you wish to change use <space> or <+> and <-> to cycle through the various options permitted. Numeric values can also be altered by using <enter> and typing a new value.

Use <backspace> to change to the lowest numeric value or first option.

Some information must be entered by typing it in rather than using <space>, e.g. telephone numbers. Move to the item to be changed and press <enter>. A prompt will appear at the bottom of the screen requesting the information.

The options listed in figure 7 are as follows.

CHAPTER 2

MENU SYSTEM

- System Setup** This function allows you to set the system mode, name, password and time. There are also options to save and recall settings and restore default settings. Another option allows the FLASH to be reprogrammed for software update. Configuration of IP address (for Telnet and FTP) is also included.
- Hardware Setup** This function allows you to set up the communications ports, and various other hardware functions of **arcaplex|Horizon**.
- Software Setup** This function allows you to change the operation of **arcaplex|Horizon** by enabling and disabling ports/channels, setting up numbers and semi-permanent connections etc.
- Analyser Setup** This function allows you to operate the protocol analyser.

MENU SYSTEM

System Setup Screen

On selecting this option the user is presented with the screen of figure 8.

To change the fields in System Setup highlight the required field and cycle through the options using the <space>. The fields are listed below :-

```
System Setup

System Mode      xxxx
System Name      xxxx
System Password  xxxx
System Time      xxxx
IP Setup
Restore defaults
Save settings
Recall settings
Reprogram FLASH
Reprogram Analogue
```

Fig 8 System Setup Menu

System Mode

This option switches **arcaplex|Horizon** between user and supervisor modes. A password is requested for supervisor mode unless there is no password stored.

In user mode access to the menus is read only.

System Name

This option allows **arcaplex|Horizon** to be given a name. If a name has been given it is displayed on the copyright screen and is used as the prompt for the command line user interface. The name can be up to 15 characters in length.

NB Use <BACKSPACE> to delete the name.

CHAPTER 2

MENU SYSTEM

System Password This option allows a password to be set up so that it has to be entered before supervisor mode can be selected. It is hidden in user mode.

NB Use <BACKSPACE> to delete the password.

System Time This option allows the time to be set. If a real time clock is detected a date can also be entered. This time is used for the protocol analyser.

IP Setup This option brings up a menu which allows IP addressing to be configured. 2 modes are available –*auto* and *fixed*.

Auto mode means that *IP address*, *subnet mask* and *gateway* are configured automatically by **arcaplex|Horizon** by requesting values from a BOOTP or DHCP server on the network. This is the default mode. It allows **arcaplex|Horizon** to be used via Telnet without the user having knowledge of free IP addresses on the network.

NB the automatically configured settings can be viewed using the *status system* command. It should be remembered that these settings may change if **arcaplex|Horizon** is switched off and on or disconnected from the network.

Fixed mode means that *IP address*, *subnet mask* and *gateway* are configured in the menu. It is important to ensure that the *IP address* is unique. If the subnet mask is not known set it to '0.0.0.0'. If no gateway is to be used set it to '0.0.0.0'

It is generally best to use the *fixed* mode.

Changes to *IP address*, *subnet mask*, *gateway* have no effect until escape is pressed.

MENU SYSTEM

The menu also allows up to 3 target IP addresses for SNMP traps to be defined. More information on SNMP is given in an [appendix](#).

Restore Defaults This option restores the factory default settings. Confirmation is requested before the settings are changed. If the saved setting for the terminal baud rate etc is different to the current setting an option to use the current terminal setting is given.

Save Settings This option saves the current settings for future recall. Confirmation is requested before the saved settings are changed. These saved settings can be recalled at any time, even if the power has been switched off and on.

NB **arcaplex|Horizon** has 2 areas to store settings so that they are not lost on power down.

1) Current settings

This area holds the current settings. It is updated when any settings change is made and is reloaded on power up.

2) Saved settings

This area holds the saved settings which are saved and recalled by using this menu.

Recall Settings This option allows the saved settings to be restored. Confirmation is requested before the settings are changed. If the saved setting for the terminal baud rate etc is different to the current setting an option to use the current terminal setting is given.

Reprogram FLASH This option allows **arcaplex|Horizon** to be reprogrammed with new software. More details are given in an [appendix](#).

Reprogram Analogue This option allows an **arcaplex|Horizon** analogue card or a DSP module on an **arcaplex|Horizon** analogue card to be

CHAPTER 2

MENU SYSTEM

reprogrammed with new software. More details are given in an [appendix](#).

Command line equivalents

System Mode	supervisor / user
System Name	read / set name
System Password	read / set password
System Time	read / set date read / set time
IP Setup	read / set ip read / set target
Restore Defaults	Default
Save Settings	Save
Recall Settings	Recall
Reprogram FLASH	swl
Reprogram Analogue	swl analogue

MENU SYSTEM

Hardware Setup Screen

On selecting this option the user is presented with the screen of figure 9.

To change the fields in Hardware Setup highlight the required field and cycle through the options using the <space>. The fields are listed below :-

```
Hardware Setup

Coms Port Baud Rate          xxxx
Coms Port Parity            xxxx
Coms Port Stop Bits         xxxx
Coms Port Data Bits         xxxx
Terminal type                xxxx
BRI S/U Power Feed          xxxx
BRI S Power Mode            xxxx
BRI U Power Mode            xxxx
BRI U Power Restart         xxxx
BRI S Bus Timing            xxxx
PRI E1/T1 Mode              xxxx
PRI Equaliser                xxxx
PRI E1 Mode                  xxxx
BRI T1 Mode                  xxxx
Analogue Ring Mode          xxxx
Analogue Caller ID Mode     xxxx
Analogue Disconnect Mode    xxxx
Analogue Impedance          xxxx
Analogue Start              xxxx
```

Fig 9 Hardware Setup Menu

Coms Port Parameters

These are the parameters for the control terminal i.e. baud rate, parity, stop bits and data bits. Note that changing these parameters will mean that the user will have to change the terminal setup to

CHAPTER 2

MENU SYSTEM

match.

Terminal Type	You can select a terminal type by typing <space>. Supported terminals are <i>ANSI</i> , <i>ANSI Colour</i> and <i>Wyse 50</i> .
BRI S/U Power Feed	Setting this to <i>On</i> enables power feeding to the ISDN S ₀ -interfaces and U interfaces for any terminal adapters, ISDN telephones or NT-1's that require it.
BRI S Power Feed	This field allows you to switch the power from normal mode to restricted mode, i.e. the power provided at the ISDN BRI S ₀ interface will switch polarity. This field should usually be set to <i>Normal</i> . Current limiters allow 25 mA per port in <i>normal</i> mode and 10 mA per port in <i>restricted</i> mode. This is equivalent to 1 W and 400 mW at 40 V. If either current limit is exceeded the power will be cut off and the P and B lights for the port will flash alternately. The power will be restarted after 10 seconds.
BRI U Power Feed	Current limiters on the U interfaces allow 15 mA per port in <i>sealing</i> mode and 50 mA per port in <i>normal</i> mode. In normal mode current will cut off after 2 seconds of active current limiting off and the P and B lights for the port will flash alternately. The power will be restarted after 30 seconds if <i>BRI U Power Restart</i> is set to <i>Normal</i> . This field should be set to <i>sealing</i> unless the terminal equipment is designed to be line powered.
BRI U Power Restart	This field controls the restarting of U interface power feeding in <i>normal</i> (50mA limit) mode. If it is set to <i>normal</i> power is restarted after 30 seconds. If it is set to <i>off</i> it is not restarted.
BRI S Bus Timing	In NT mode using an S interface this field will switch between <i>adaptive</i> timing and <i>fixed</i> timing on the S ₀ interface. Use adaptive timing if the S ₀ interfaces have a long cable attached.

MENU SYSTEM

PRI E1/T1 Mode	This field allows you to set the PRI interfaces to E1 or T1.
PRI Equaliser	This field allows you to enable an equaliser on the PRI ports which allows them to work over longer cable lengths.
PRI E1 Mode	This field allows you to set the line code, framing standard and international (Si) bit usage on E1 interfaces.
PRI T1 Mode	This field allows you to set the line code and framing standard on T1 interfaces. It is currently fixed as <i>ESF/B8ZS</i> .
Analogue Ring Mode	<p>This field allows you to set the characteristics of the ringing voltage on analogue interfaces. If it is set to <i>Normal</i> the ringing is 25 Hz with a dual cadence of 0.4s on, 0.4s off alternating with 0.4s on, 2s off. If it is set to <i>USA</i> the ringing is 20Hz with a cadence of 2s on, 4s off. If it is set to <i>Custom</i> then you can press enter which allows you to set the frequency (16/20/25/50 Hz) and 3 cadences. Cadence 1 is for the initial ring. Cadence 2 and Cadence 3 are alternated after the initial ring. Cadences should be entered in the form a/b where a is on time in 50ms units and b is off time in 50ms units. Set a cadence to 0/0 if it is not required. A cadence with either the on time or the off time (but not both) set to zero is invalid</p>
Analogue Caller ID Mode	<p>This field allows you to set the format of the caller ID signal on analogue interfaces. <i>FSK (ETSI)</i> is for European telephones and <i>FSK (Bellcore)</i> is for American telephones. It can also be set to <i>Off</i> to disable it or <i>DTMF</i>.</p> <p>Note: Caller ID is currently disabled if <i>Analogue Start Mode</i> is set to <i>Ground Start</i>.</p>
Analogue Disconnect Mode	This field allows you to set the change in the line state that occurs for 0.5 seconds when the network is disconnecting the call. It is

CHAPTER 2

MENU SYSTEM

normally set to *Line break* but can be changed to *Line reversal* or *Line unchanged*.

Analogue Impedance

This field allows you to select the impedance set to match equipment designed for a particular country. Countries currently supported are *UK*, *USA* and *Germany*. There is also an ETSI set and a 600 ohm set.

Analogue Start

This field allows you to set analogue lines to *Normal* (for ordinary telephone equipment) and *Ground Start* (for some PBX's).

Command line equivalents

Coms Port Baud Rate	read / set communication
Coms Port Parity	read / set communication
Coms Port Stop Bits	read / set communication
Coms Port Data Bits	read / set communication
Terminal Type	read / set terminal
BRI S/U Power Feed	read / set power bri
BRI S Power Mode	read / set power s
BRI U Power Mode	read / set power u
BRI U Power Restart	read / set power restart
BRI S Bus Timing	read / set s
PRI E1/T1 Mode	read / set mode pri
PRI Equaliser	read / set mode equaliser
PRI E1 Mode	read / set e1
PRI T1 Mode	read / set t1
Analogue Ring Mode	read / set analogue ring
Analogue Caller ID Mode	read / set analogue clid
Analogue Disconnect Mode	read / set analogue disconnect
Analogue Impedance	read / set analogue impedance
Analogue Start	read / set analogue start

MENU SYSTEM

Software Setup Screen

On selecting this option the user is presented with the screen of figure 10.

To change the fields in Software Setup highlight the required field and cycle through the options using the <space>. The fields are listed below :-

NB some options are not shown depending on the protocol, routing and CLID mode selected.

```
Software Setup

Protocol          xxxx
Routing Mode     xxxx
Datalink Setup
Channel Setup
Connection Setup
Number Setup
Routing Setup
CLID Generation  xxxx
CLID Number type xxxx
CLID Screening type xxxx
Use Internal Tones xxxx
BRI Require SPID  xxxx
BRI HOLD Reserve Channel xxxx
Numbering plan   xxxx
```

Fig 10 Software Setup Menu

Protocol

This option selects the protocol used on all ISDN connections. The options are *ETSI EuroISDN* and *National ISDN*.

Routing Mode (ETSI protocol only)

This option selects the routing mode used to route calls. The options are *Number*, *Channel* and *Fixed*.

CHAPTER 2

MENU SYSTEM

If it is set to *number* outgoing calls are routed to the first free b channel on PRI 1 and incoming calls are routed by Called Party Number to the first free B channel on a matching BRI or the first free B channel on PRI 2 if there is no match.

If it is set to *channel* calls are routed by b channel according to the routing table (see *Routing Setup*).

If it is set to *fixed* outgoing calls are routed to the first free b channel on PRI 1 and incoming calls are routed by Called Party Number to a specific B channel (see *Number Setup*) on a matching BRI or the first free B channel on PRI 2 if there is no match.

NB in National ISDN mode outgoing calls are routed to the first free b channel on PRI 1 and incoming calls are routed by Called Party Number to the first free B channel on a matching BRI or the first free B channel on PRI 2 if there is no match.

Datalink Setup

This option brings up a menu which allows the datalink mode of individual BRI's to be set up

If it is set to *point to point* only 1 TA can be fitted on each BRI. The TA should have a fixed TEI of 0.

If it is set to *point to multipoint* 8 TA's can be fitted on each BRI. (with National ISDN protocol this is effectively limited to 2 since only 2 SPID's per BRI are supported).

For most terminal equipment *point to multipoint* should be used. For some PBX's *point to point* should be used.

Channel Setup

This option brings up menus which allow the number of channels to be used for calls on each interface to be set up. Use the cursor keys and <ENTER> to select the interface type and then use the

MENU SYSTEM

cursor keys to select the interface to be set up. Use <SPACE> to change the number of channels required. <BACKSPACE> can be used to make the number of channels 0.

For primary rate interfaces the range is 0-30 for E1 and 0-23 for T1. For basic rate interfaces the range is 0-2.

e.g. if the number of channels for PRI 2 is set to 6 then b1-b6 can be used for calls provided they are not assigned to semi-permanent connections.

The values in Channel Setup should meet the following formula to ensure that there are enough channels on PRI 1 for all the calls that can be made. For simplicity this formula assumes no semi-permanent connections are set up on channels enabled for calls.

$$\begin{aligned} & (\text{no. of BRI channels enabled}) \\ & + (\text{no. of channels enabled on PRI 2}) \\ & \leq (\text{no. of channels enabled on PRI 1}) \end{aligned}$$

Calls on hold release the b channel on the BRI if there is a spare channel on PRI 1 or it is the first call on hold with b channel reserve on (always on for ETSI protocol). This ensures that calls on hold do not prevent other BRI's from having access to 2 b channels on PRI 1. NB the b channel is not released if *Routing Mode* is set to *channel* or *fixed*.

The number of spare channels on PRI 1 is

$$\begin{aligned} & (\text{no. of channels enabled on PRI 1}) \\ & - (\text{no. of BRI channels enabled}) \\ & - (\text{no. of channels enabled on PRI 2}) \end{aligned}$$

Connection Setup

This option brings up menus which allow semi-permanent connections to be set up. Use the cursor keys and <ENTER> to select either PRI 1 or PRI 2 and then use the cursor keys to select the timeslot to be set up. Use <SPACE> to cycle through 1

CHAPTER 2

MENU SYSTEM

channel at a time. Use <#> to cycle through 1 port at a time. Use <BACKSPACE> to set to *unallocated*.

Connections can be made between PRI 1 and PRI 2 or any BRI. This is to allow leased line connections to be set up.

Connections can also be made between PRI 2 and any BRI. This is to allow a router to be connected.

The timeslot on PRI 2 assigned to the d channel (16 for E1, 24 for T1) can be assigned a semi-permanent connection. If this is done no calls can be made on PRI 2.

If a connection clashes with another connection a '#' is displayed and the connection must be changed before another connection can be modified or the menu exited.

Changes to the connections have no affect until escape is pressed to exit the connection menu.

Routing Setup

This option brings up a menu which allows b channels on PRI 1 to be assigned to b channels on PRI 2 or b channels on BRI's. It is not displayed if *Routing Mode* is set to *Number*.

NB The timeslots on PRI 1 and 2 assigned to the d channel (16 for E1, 24 for T1) cannot be used.

Use the cursor keys to select the timeslot to be set up. Use <SPACE> to cycle through 1 channel at a time. Use <#> to cycle through 1 port at a time. Use <BACKSPACE> to set to *unallocated*.

If a route clashes with another route a '#' is displayed and the route must be changed before another route can be modified or the menu exited.

MENU SYSTEM

The relevant channels have to be enabled for calls to be made (see *Channel Setup*).

A command line option (*auto route*) allows the routing table to be generated quickly based on channels enabled in *Channel Setup*.

Changes to this menu have no affect until escape is pressed to exit it.

Number Setup (ETSI protocol)

This option brings up menus which allow numbers to be assigned to the basic rate interfaces. Use the cursor keys and <ENTER> to select the number to be changed. Use <ENTER> to change the number. Use <BACKSPACE> to delete a number.

10 numbers can be set up for each basic rate interface, 5 numbers can be set up for each analogue interface and 1 number can be set up for PRI 2.

The numbers used for ETSI protocol and National ISDN protocol are stored separately. The correct protocol should be selected before changing the numbers.

Some examples for numbers are given in an [appendix](#).

Numbers can include '?' if that digit is to be ignored in the number comparison. Numbers can also have a '*' OR '+' at the end of the number if extra digits at the end of the number are to be acceptable.

A subaddress can be included by adding a '#' followed by the subaddress. The subaddress can't include '?', '+' or '*'. If a subaddress only is to be stored use ?# followed by the subaddress.

Numbers can have an 'r' at the end of the number (or

CHAPTER 2

MENU SYSTEM

number#subaddress) if the calling party number on outgoing calls is to have the presentation indicator set to restricted. NB this applies only if CLID generation is on.

The numbers in Number Setup have 2 purposes :

(i) Choosing the port to send a call to.

(This does not apply if *Routing Mode* is set to *channel*)

This depends on the network providing a Called Party Number in the SETUP message. This can be either a full number or the last few digits. It also depends on the network routing several numbers to **arcaplex|Horizon**. This requires Multiple Subscriber Numbering (MSN) or Direct Dialling In (DDI) to be provided by the network. Alternatively a single number with subaddresses is acceptable. In this case the network needs to provide Called Party Subaddress as well as Called Party Number in the SETUP message.

The numbers (ignoring any subaddress) are compared with the end of the Called Party Number. They should be at least as long as the part of the number that is different between each number but not longer than the Called Party Number provided by the network. If the number includes a subaddress then this is checked for an exact match with the Called Party Subaddress.

If *Routing Mode* is set to *number* incoming calls are routed to the first matching BRI with a free b channel or analogue interface. If there are no matching ports they are routed to a free b channel on the PRI port. If this also fails the call is rejected.

If *Routing Mode* is set to *fixed* incoming calls are routed to the first matching BRI b channel number or analogue interface. NB for BRI numbers (1) is for b1, (2) is for b2, (3)-(10) are ignored. If there are no matching ports they are routed to a free b channel on

MENU SYSTEM

the PRI port. If this also fails the call is rejected.

NB the number entered for PRI 2 has no effect on the routing of the call.

If the matched number ends in '+' then the Called Party Number (except any extra digits) is not sent to the BRI.

(ii) Calling Line Identification.

This applies if CLID Generation is set to Yes. **arcaplex|Horizon** adds or changes the Calling Party Number in SETUP messages to the network.

If there is a Calling Party Number in the SETUP message from the terminal and it matches one of the numbers for that port then it is passed through unchanged. Otherwise the first number for that port is used. If it is blank then the Calling Party Number (if any) is passed through unchanged. If it contains '?' these are replaced by '0'. If it ends in '*' or '+' the '*' or '+' is omitted.

Only an exact match with the Calling Party Number is accepted by the latest software (v1.3t or later). Earlier software versions compared the stored number with the end of the Calling Party Number.

If the Calling Party Number in the SETUP message from the terminal doesn't match but is no more than 5 digits and the first number for that port ends in '*' then the Calling Party Number from the SETUP message is added to the first number for that port. This is useful for PBX's where the extension number is provided as the Calling Party Number.

Number Setup (National ISDN protocol)

This option brings up menus which allow numbers to be assigned to the basic rate interfaces. Use the cursor keys and <ENTER> to

CHAPTER 2

MENU SYSTEM

select the number to be changed. Use <ENTER> to change the number. Use <BACKSPACE> to delete a number.

2 numbers can be set up for each basic rate interface, 1 number can be set up for each analogue interface and 1 number can be set up for PRI 2.

The numbers used for ETSI protocol and National ISDN protocol are stored separately. The correct protocol should be selected before changing the numbers.

Some examples for numbers are given in an [appendix](#).

The match numbers in *Number Setup* have 2 purposes :

(i) Choosing the port to send a call to.

Two match numbers (a) and (b) can be set up for each BRI port. They are for 2 separate TA's or for 1 TA that uses 2 SPID's.

The *match numbers* should be chosen from the *directory numbers* for the PRI line. The *match number* set up for the BRI TA acts as the *directory number* for the BRI TA. The *Service Profile Identifier (SPID)* for a BRI TA is equal to the *match number* with 0101 added. This is the *generic SPID* format from Bellcore National ISDN 97.

NB The match numbers should all be different.

Incoming calls have the *Called Party Number* in the *SETUP* message compared with the *match numbers*. The call is routed to the BRI TA with a matching *match number*. If there is no matching *match number* the call is routed to a free b channel on the PRI port. If this also fails the call is rejected.

NB the number entered for PRI 2 has no effect on the routing of

MENU SYSTEM

the call.

(ii) Calling Line Identification.

This applies if *CLID Generation* is set to *Yes*. **arcaplex|Horizon** adds or changes the *Calling Party Number* in *SETUP* messages to the network.

The menu includes a CLID number for PRI 2 and match numbers for the BRI's. The match numbers also act as CLID numbers.

If there is a *Calling Party Number* in the *SETUP* message from the terminal and it matches one the CLID numbers for that TA then it is passed through unchanged. Otherwise the CLID number for that TA is used.

If the TA is not SPID initialised then all the CLID numbers for that port are checked. If there is no match the CLID number for the first TA is used. If it is blank then the *Calling Party Number* (if any) is passed through unchanged.

CLID Generation

This option allows the port (PRI 2, a BRI or analogue line) from which a call is made to be detected by the network. When it is set to *Yes* outgoing calls have their *Calling Party Number* checked against the numbers in *Number Setup*. If it is not present it is added. If it is incorrect it is replaced.

CLID Number type (only if CLID generation on)

This option allows the choice of number type and plan in the calling party number when CLID generation is on to be configured.

If it is set to *Normal* it is unchanged if number passed, set to unknown type / unknown plan if number changed).

If it is set to *National* it is always set to national type / ISDN/telephony plan.

NB if it is set to national the numbers in number setup should be

CHAPTER 2

MENU SYSTEM

the national number (area code without prefix digit followed by local number)

CLID Screening type
(only if CLID generation on)

This option allows the choice of screening indicator in the calling party number when CLID generation is on to be configured.

If it is set to *Normal* it is unchanged if number passed, set to user-provided /not screened if number changed).

If it is set to *National* it is always set to network generated

Use Internal Tones
(ETSI protocol only)

This option allows the source of tones (dial, error, busy and ring) for calls to/from the basic rate ports to be selected.

If it is set to *No* the network provided tones are used.

If it is set to *Yes* then the internal tones for dial, error and ring are used for outgoing calls (error is also used for incoming calls on an analogue port) and the internal tone for ring is used for incoming calls. NB the ring tone for incoming calls is provided to the network. All other tones are provided to the local TA/telephone.

If it is set to *Auto* then the internal or network provided tones are used depending on the presence of a progress indicator.

NB for National ISDN protocol it is set to yes but not displayed.

BRI Require SPID
(National ISDN protocol only)

This option controls how calls to/from uninitialised BRI TA's are handled. If it is set to *Yes* they are blocked.

An uninitialised BRI TA is one that has not provided a valid SPID.

BRI HOLD Reserve Channel
(National ISDN protocol only)

If this option is set to *Yes* one b channel on the BRI is kept free if one or more calls are on hold with no specific b channel reserved on that BRI. Hence at least one of the calls can be retrieved at all

MENU SYSTEM

times.

NB for ETSI protocol it is set to yes but not displayed.

Numbering plan (National ISDN protocol only)

This option sets how **arcaplex|Horizon** decides to stop waiting for more digits when keypad dialling is being used. This is necessary since National ISDN does not support overlap dialling on PRI lines. The dialled digits have to be stored until the whole number is received.

If it is set to *Unknown* the number is assumed complete 10 seconds after the last digit is received.

If it is set to *N.America* the number format is known for local, national, special and N11 numbers and the number is assumed complete after 0, 4 and 20 seconds as appropriate. Since the number format is not known for international numbers in this case the number is assumed complete 10 seconds after the last digit is received.

With either setting dialling '#' after the number indicates that the number is complete.

The *N.America* setting should be used for the countries that share the international code of '1'. These are USA, Canada, Bahamas, Barbados, Bermuda, Caribbean, Puerto Rico and US Virgin Islands. Otherwise the *Unknown* setting should be used.

Command line equivalents

Protocol	read / set mode protocol
Routing Mode	read / set mode route
Datalink Setup	read / set mode bri
Channel Setup	read / set channels pri read / set channels bri
Connection Setup	read / set connection pri
Routing Setup	read / set route

CHAPTER 2

MENU SYSTEM

Number Setup	read / set number pri read / set number bri
CLID Generation	read / set mode clid
CLID Number Type	read / set mode number
CLID Screening Type	read / set mode screening
Use Internal Tones	read / set mode tone
BRI Require SPID	read / set mode spid
BRI HOLD Reserve Channel	read / set mode reserve
Numbering plan	read / set mode plan

MENU SYSTEM

Analyser Setup Screen On selecting this option the user is presented with the screen of figure 11.

To change the fields in Figure 7 highlight the required field and cycle through the options using the <space>. The fields are listed below :-

```
Analyser Setup

Layer 1 Hardware      xxxx
Layer 2 Data Link    xxxx
Layer 3 Call Control  xxxx
Channel Filter
Call Reference Filter  xxxx
Analyser Specification  xxxx
Activate Analyser
```

Fig 11 Analyser Setup Menu

- Layer 1 Hardware** This option allows the reporting level for layer 1 to be selected. The options are *OFF* and *ASCII Short Display*.
- Layer 2 Data Link** This option allows the reporting level for layer 2 to be selected. The options are *OFF*, *HEX Display*, *ASCII Short Display* and *ASCII Long Display*.
- Layer 3 Call Control** This option allows the reporting level for layer 3 to be selected. The options are *OFF*, *HEX Display*, *ASCII Short Display* and *ASCII Long Display*.

CHAPTER 2

MENU SYSTEM

Channel Filter This option brings up a menu which allows reporting for individual basic rate and primary rate interfaces to be enabled/disabled.

Call Reference Filter This option allows reporting at layer 3 to be limited to a single call reference. Use <SPACE> to disable the call reference filter.

Analyser Specification This option tells the analyser which protocol it should assume when decoding the messages. The protocols that can be decoded are CCITT (general purpose), BTNR191 (UK), AT&T 5ESS (USA), NT DMS100 (USA), National ISDN 1 (USA), 1TR6 (Germany) and VN2/3 (France), ETSI (Europe).

Activate Analyser This option clears the screen and activates the analyser. To exit analyser mode press <esc>.

See chapter 3 - [Protocol Analyser](#) for a description of the analyser trace display and the commands that can be used to scroll through the trace.

Command line equivalents

Layer 1 Hardware	read / set analyser l1
Layer 2 Data Link	read / set analyser l2
Layer 3 Call Control	read / set analyser l3
Channel Filter	read / set analyser pri read / set analyser bri
Call Reference Filter	read / set analyser reference
Analyser Specification	read / set analyser protocol
Activate Analyser	analyser

PROTOCOL ANALYSER

Introduction The Protocol Analyser is a useful feature for checking the operation of **arcaplex|Horizon**. It allows the ISDN protocol on each interface to be checked.

The analyser is operated using the Analyser Setup Menu (see chapter 2 - [Menu System](#)).

This section describes the display of the analyser trace and the commands that can be used to scroll through the trace.

Information Provided at Layer 1 A typical display of a layer 1 message is shown below.

```
23: Ch BRI 1 L1 STATE= Activated
    00:01:75:30.271
```

The information presented is outlined below.

(a) Sequence Number

Each message has a unique sequence number so that old messages can be easily located.

(b) Channel Number

The channel number (e.g.BRI 1) on which the event occurred.

(c) Layer Number

The layer on which the event is being reported.

(d) State

The new state of the physical layer e.g. Activated.

PROTOCOL ANALYSER

(e) Timestamp

The time that the message was recorded. The timestamp has the form dd:hh:mm:ss.nnn where dd represents days, hh hours, mm minutes, ss seconds and nnn milliseconds.

Note that layer 1 messages are generated only if a change occurs in the state of the physical link.

Information Provided at Layer 2

A typical display of a short ASCII layer 2 message is shown below.

```
23: TA Ch BRI 2 L2                00:01:75:30.271

SAPI= 0, TEI= 40, C/R= 0, P/F=1, TYPE= SABME
```

The information presented is outlined below.

(a) Sequence Number

Each message has a unique number so that old messages can be easily located.

(b) Originator

This field reports which side generated the message. For PRI 1 the text is MUX for ISDN Multiplexer (**arcaplex|Horizon**) generated messages and NET for messages generated by the network (exchange or switch). On the other ports the text is TA for terminal generated messages and MUX for messages generated by the ISDN Multiplexer (**arcaplex|Horizon**).

(c) Channel Number

The channel number (e.g. BRI 1) on which the event occurred.

CHAPTER 3

PROTOCOL ANALYSER

(d) Layer Number

The layer on which the event is being reported.

(e) Timestamp

The time that the message was generated (NT message) or received (TE message). The timestamp has the form dd:hh:mm:ss.nnn where dd represents days, hh hours, mm minutes, ss seconds and nnn milliseconds.

(f) Service Access Point Identifier*

(g) Terminal Endpoint Identifier*

(h) Command/Response Bit*

(i) Poll/Final Bit*

(j) Type*

The message type, being one off I, RR, RNR, REJ, SABME, DM, UI, DISC, UA, FRMR, XID.

A typical display of a long ASCII layer 2 message is shown below.

```
23: TA Ch BRI 2 L2
SAPI= 0, TEI= 40, C/R= 0, P/F=1, TYPE= INFO
N(R)= 1, N(s)= 1
```

The following information has been added:

(k) Send Sequence Number N(s)*

PROTOCOL ANALYSER

(l) Receive Sequence Number N(r)*

Layer 2 management transactions may be also decoded in long form messages. A typical decode follows.

```
23: TA Ch BRI 2 L2                00:01:75:30.271
SAPI= 0, TEI= 40, C/R= 0, P/F=1, TYPE= UI
MEI= 15, Ri= 7FCD, MSG TYPE= ID Request, Ai= 0
```

The following information has been added:

(m) Management Entity Identifier*

(n) Reference Number (Ri)*

(o) Management Message Type*

One of ID Request, ID Assigned, ID Denied, ID Check Request, ID Check Response, ID Remove, ID Verify.

(p) Action Indicator*

Only Information and certain Unnumbered Information messages at layer 2 include layer 3 messages.

Fields marked with * are explained further in CCITT Q.921 Digital Subscriber Signaling System No 1, Data Link Layer.

A typical display of a hex layer 2 message is shown below.

```
23: TA Ch BRI 2 L2                00:01:75:30.271

02 81 00 02 41 01 81 0D 18 01 89
```

CHAPTER 3

PROTOCOL ANALYSER

The information contained in the message is not decoded but simply displayed as hex octets.

Information Provided at Layer 3

A typical display of a short ASCII layer 3 message is shown below.

```
23: TA Ch BRI 1 L3                00:01:75:30.271

PD= 65, LEN= 1, FLAG= Orig, CALL REF= 3, TYPE= SETUP
```

The information presented is outlined below.

(a) Sequence Number

Each message has a unique sequence number so that old messages can be easily located.

(b) Originator

This field reports which side generated the message. For PRI 1 the text is MUX for ISDN Multiplexer (**arcaplex|Horizon**) generated messages and NET for messages generated by the network (exchange or switch). On the other ports the text is TA for terminal generated messages and MUX for messages generated by the ISDN Multiplexer (**arcaplex|Horizon**).

(c) Channel Number

The channel number (e.g. BRI 1) on which the event occurred.

(d) Layer Number

The layer on which the event is being reported.

PROTOCOL ANALYSER

(e) Timestamp

The time that the message was generated (NT message) or received (TE message). The timestamp has the form dd:hh:mm:ss.nnn where dd represents days, hh hours, mm minutes, ss seconds and nnn milliseconds.

(f) Protocol Discriminator*

(g) Call Reference*

The call reference consists of three parts, the Length of the call reference, the Value of the call reference and the Originator of the call reference.

(h) Message Type*

One of the Q.931 supported messages, or network specific message.

A typical display of a long ASCII layer 3 message is shown below.

```
23: TA Ch BRI 1 L3                00:01:75:30.271
PD= 65, LEN= 1, FLAG= Orig, CALL REF= 3, TYPE= SETUP
CALLING PARTY NUMBER:0 LENGTH= 7
TYPE= Unknown PLAN= ISDN/Telephony NUMBER= '234231'
CALLED PARTY NUMBER:0 LENGTH= 7
TYPE= Unknown PLAN= ISDN/Telephony NUMBER= '384020'
```

In the long ASCII message decode all the information elements contained in the message are decoded. Information elements are separated by a blank line, the information element name together with relevant codeset and length appears as a heading above each information element decode and the decoded information is

CHAPTER 3

PROTOCOL ANALYSER

indented by 1 space.

For more information on * marked fields, messages and information elements refer to CCITT Q.931 Digital Subscriber Signaling System No 1, Network Layer.

A typical display of a hex layer 3 message is shown below.

```
23: TA Ch BRI 2 L2           00:01:75:30.271
41 01 81 0D 18 01 89
```

The information contained in the message is not decoded but simply displayed as hex octets.

PROTOCOL ANALYSER

Analyser Commands

As soon as you enter analyser mode stored messages (if there are any) are displayed in accordance with the analyser options selected. You may enter <esc> to exit analyser mode, change the decode options and enter analyser mode again without losing any messages. The options available are:-

(a) <m> - Manual Mode

The analyser enters manual mode. Automatic display of incoming messages is stopped and the user can review the messages in the message buffer. Pressing M again will leave manual mode.

(b) <home> or - Go to First Message

Will display messages starting at the oldest message in the buffer. This command works in manual and automatic modes.

(c) <end> or <e>- Go to Last Message

Will go to the last message in the buffer and display any new messages which arrive. This command works in manual and automatic modes.

(d) <up> or <u> - Review Previous Message

Will display the message which arrived just before the last message displayed. This command works only in manual mode.

(e) <down> or <d> - Go to Next Message

Will display the message which arrived just after the last message displayed. This command works only in manual mode.

(f) <c> - Clear Buffer

CHAPTER 3

PROTOCOL ANALYSER

Will remove all messages from the buffer. This command works in manual and automatic modes.

(g) <h> - Pause Display

Will pause a scrolling display. Pressing <h> will start the display scrolling again.

Note that whenever an attempt is made to move to a message beyond the start or end of the message buffer a beep will be sent to the terminal.

COMMAND LINE INTERFACE

Introduction

The command line interface is an alternative user interface to the menu system. All menu items have an equivalent command.

The command line interface can be accessed via the serial port, via the (optional) modem or (by using Telnet) via the Ethernet port.

There are some commands that have no equivalent in the menu system. These are **debug**, **history**, **test**, **trace**, **upload**, the **reset** commands and the **restart** commands.

As with the menu system there are 2 modes - user and super. There are many commands that can only be used in super mode. These are **upload**, **diagnostic**, **swl**, all **set** commands, all **reset** commands, all **restart** commands and **read password**.

Some commands only apply when National ISDN protocol is selected. They are **set mode reserve**, **set mode route**, **set mode spid** and **set mode plan**.

One command applies only when ETSI protocol is selected. It is **set mode tone**.

Some commands apply only if ETSI protocol is selected and Routing Mode is set to Channel. They are **set route pri** and **auto route**.

Two commands apply only if CLID generation is enabled. They are **set mode number** and **set mode screening**.

Commands will not be accepted if they refer to a port that is not fitted.

One command – **diagnostic** is not available when using Telnet.

COMMAND LINE INTERFACE

Syntax Commands are shown in full. When part of a word is in lower case only the upper case part is required.

Commands are not case sensitive. Commands typed as upper case are displayed as lower case.

Commands must include a space between each word.

When number(s) are specified individual numbers or groups of numbers in the specified range are acceptable (no spaces allowed)

e.g. 1-15

1-2,3,6-8

1,4,9

all is accepted for a number range.

yes and **no** are accepted as pseudonyms for **on** and **off**.

rem can be used at the start of a command so that it is ignored.

Read commands All **set** commands have an equivalent **read** command. This is normally the **set** command with **set** replaced by **read** and the last parameter omitted.

e.g. **set power bri on** has an equivalent read command **read power bri**.

Groups of settings can be read by a shortened form

e.g. **read power** is equivalent to **read power bri** followed by **read power s** followed by **read power u**

Help commands There are **help** commands provided to show the syntax of every command except read commands.

All **set** commands have an equivalent **help** command. This is normally the **set** command with **set** replaced by **help** and the last parameter omitted.

e.g. **set power bri on** has an equivalent read command **help power bri**.

Help on groups of **set** commands can be read by a shortened form

CHAPTER 4

COMMAND LINE INTERFACE

e.g. **help power** is equivalent to **help power bri** followed by **help power restart** followed by **help power s** followed by **help power u**

Typing **help** on its own gives a full list of commands.

Command rota

Previous commands can be selected for use again using the up and down cursor keys. This requires terminal emulation to be set correctly.

COMMAND LINE INTERFACE

List of commands

- analyser
- auto route
- cls
- debug analogue
- debug bri
- debug pri
- diagnostic
- help commands*
- history
- menu
- read commands*
- recall
- reset system
- reset l1 bri
- reset l1 pri
- reset l3 analogue
- reset l3 bri
- reset l3 pri
- restart bri
- restart pri
- save
- set analogue clid
- set analogue disconnect
- set analogue impedance
- set analogue ring
- set analogue start
- set analyser bri
- set analyser l1
- set analyser l2
- set analyser l3
- set analyser pri
- set analyser protocol
- set analyser reference
- set channels analogue

CHAPTER 4

COMMAND LINE INTERFACE

set channels bri
set channels pri
set communication
set connection pri
set date
set e1
set ip
set mode bri
set mode clid
set mode protocol
set mode plan
set mode pri
set mode reserve
set mode route
set mode tone
set mode spid
set name
set number bri
set number pri
set password
set power bri
set power restart
set power s
set power u
set route pri
set s
set t1
set time
start l1 bri
start l2 bri
start l2 pri
status
status bri
status pri
status system

COMMAND LINE INTERFACE

supervisor
swl (software load)
swl analogue
trace
upload
user
version

COMMAND LINE INTERFACE

ANALYSER command Clears the screen and enables protocol analyser display.

Syntax ANALYser

Examples mux [U]> analyser

```
3 : TA Ch BRI1 L3                                00:16:14:12.173
      PD= 8, LEN= 1, FLAG= Orig, CALL REF= 1 SETUP

4 : MUX Ch PRI1 L3                                00:16:14:12.217
      PD= 8, LEN= 2, FLAG= Orig, CALL REF= 4 SETUP

7 : NET Ch PRI1 L3                                00:16:14:12.285
      PD= 8, LEN= 2, FLAG= Dest, CALL REF= 4 SETUP ACKNOWLEDGE

9 : MUX Ch BRI1 L3                                00:16:14:12.316
      PD= 8, LEN= 1, FLAG= Dest, CALL REF= 1 SETUP ACKNOWLEDGE
```

Related commands

- set analyser l1
- set analyser l2
- set analyser l3
- set analyser bri
- set analyser pri
- set analyser reference
- set analyser protocol
- trace

Menu Equivalent Analyser Setup
- Activate Analyser

COMMAND LINE INTERFACE

AUTO ROUTE command	<p>Generates a routing table based on channel setup. (ETSI protocol only - also requires routing mode to be channel)</p> <p>Channels on PRI 1 are allocated to enabled channels on PRI 2 and enabled channels on BRI's in that order. Use <i>read route pri</i> to view the generated routing.</p> <p>If there are insufficient channels on PRI 1 to route to all the other enabled channels an error message is displayed and the existing routing table is unchanged.</p>
Syntax	AUto ROUte
Examples	mux [S]> auto route
Related commands	set mode route set route pri
Menu Equivalent	None.

COMMAND LINE INTERFACE

CLS command	Clears the terminal screen.
Syntax	CLS
Examples	mux [U]> cls
Related commands	None.
Menu Equivalent	None.

COMMAND LINE INTERFACE

DEBUG ANALOGUE command	Displays the status of an analogue port and any changes to its status until <ESCAPE> is pressed.
Syntax	DEBug Analogue [port]
	port Port number from 1 (for A1) to 32 (for A32)
Examples	<pre>mux [U]> debug analogue 11 []v12: no tei's assigned []v13: b: free [13:28:18.175]line : off hook [13:28:18.265]v12: tei 64 sapi 0 TEI assigned [13:28:18.610]v13: b: tei 64 #1 u->n (call setup) [pri 1 tei 0 #1 ts01(b1)]</pre>
Related commands	debug bri debug pri
Menu Equivalent	None.

COMMAND LINE INTERFACE

DEBUG BRI command Displays the status of a basic rate port and any changes to its status until <ESCAPE> is pressed.

Syntax **DEBUg BRI [port]**

port Port number from 1 (for BRI 1) to 16 (for BRI 16)

Examples mux [U]> **debug bri 1**

```
[          ] pwr: on
[          ] l1: active
[          ] l2: no tei's assigned
[          ] l3: b1: free
[          ] l3: b2: free
[17:22:12.817]l2: tei 64 sapi 0 TEI assigned
[17:22:12.900]l2: tei 64 sapi 0 multiple frame established
[17:22:13.003]l3: b1: tei 64 #1 u->n (call setup) [pri 1 tei 0 #2 ts01(b1) ]
[17:22:14.973]l3: b1: tei 64 #1 u->n (clearing) [pri 1 tei 0 #2 ts01(b1) ]
[17:22:17.029]l3: b1: free
[17:22:22.196]l2: tei 64 sapi 0 TEI assigned
```

Related commands debug analogue
debug pri

Menu Equivalent None.

COMMAND LINE INTERFACE

DEBUG PRI command Displays the status of a primary rate port and any changes to its status until <ESCAPE> is pressed.

Syntax **DEBUg PRi [port]**

port Port number from 1 (for PRI 1) to 2 (for PRI 2)

Examples mux [U]> **debug pri 1**

```
[          ]l1: active
[          ]l2: tei 0 sapi 0 multiple frame established
[          ]l3: ts01(b1) : tei 0 #1 u->n [bri 8 tei 0 #1 b1 (connected)]
[          ]l3: ts02(b2) : free
[          ]l3: ts03(b3) : semi-permanent connection to pri 2 ts01(b1)
                "
                "
[          ]l3: ts31(b30) : free
[17:18:05.455]l3: ts01(b1) : tei 0 #1 u->n [bri 8 tei 0 #1 b1 (clearing)]
[17:18:06.449]l3: ts01(b1) : free
[17:18:55.430]l1: not active
[17:19:00.770]l2: tei 0 sapi 0 awaiting establishment
[17:19:01.771]l2: tei 0 sapi 0 TEI assigned
[17:19:14.759]l1: active
[17:19:15.016]l2: tei 0 sapi 0 multiple frame established
```

Related commands debug analogue
debug bri

Menu Equivalent None.

COMMAND LINE INTERFACE

DEFAULT command Restores the default settings.

Syntax **DEFault**

Examples mux [S]> **default**
Restore defaults
Confirm Yes/No (Y/N)
y
Defaults restored

Related commands None

Menu Equivalent System Setup
- Restore defaults

COMMAND LINE INTERFACE

DIAGNOSTIC command Switches to diagnostic mode. An internal trace is enabled. **arcaplex|Horizon** will operate at a reduced speed in this mode. Press <D> to return to normal mode.

This command is not permitted during Telnet or modem access.

Syntax **DIAGnostic**

Examples mux [S]> **diagnostic**

```
**** Diagnostic mode ****
**** Press [D] to exit ****
-> DLE | PH-DATA-IND          | Ch=0 [8] FC FF 03 0F DB 13 01 FF
      | SAPI=3F, C/R=0, TEI=7F <UI>
-> MDL | MDL-UNITDATA-IND   | Ch=0 CEI=3F,7F [5] 0F DB 13 01 FF
----- start 60499, end 6049d -----
----- UI: Ri=DB13, Type=01, Ai=7F -----
----- ID REQ chan 0 count 10 -----
-> DLE | DL-UNITDATA-REQ     | Ch=0 CEI=3F,7F [5] 0F DB 13 02 81
      | PD=0F Ri=DB13 {ID-Assigned} Ai=40
```

Related commands None.

Menu Equivalent Press <D> from Copyright Screen (in supervisor mode).

COMMAND LINE INTERFACE

HELP commands There is an equivalent **help** command for every command (except **help** and **read** commands). The correct syntax for a command is shown.

Syntax **HElp [text]**

text a command with any values omitted

Help on groups of commands can be read by using a shortened form (see examples).

If help is required for a **set** command the word **set** can be omitted.

If **text** is omitted help is given on all commands.

Examples mux [U]>**help set power s**
SEt POWer S [NORmal|RESTRicted]

mux [U]>**help power s**
SEt POWer S [NORmal|RESTRicted]

mux [U]>**help power**
SEt POWer BRi [OFF|ON]
SEt POWer RESTART [NORmal|OFF]
SEt POWer S [NORmal|RESTRicted]
SEt POWer U [SEALing|NORmal]
mux [U]>

mux [U]>**help trace**
TRace

Related commands **set** commands
read commands

Menu Equivalent None.

HISTORY command Displays information on the last 20 calls.

NB only calls that have connected are shown. Calls are not included in the history until they are cleared.

Syntax **HIStory**

Examples mux [U]>**history**

Interface	In/Out	Calling/Called	Duration
BRI 2	OUT	384087	9
BRI 2	OUT	384087	5
BRI 2	OUT	384087	21
BRI 2	OUT	384060	9
BRI 2	OUT	384060	11

Related commands None.

Menu Equivalent None.

COMMAND LINE INTERFACE

MENU command	Switches from command line interface to menu system. Press <ESCAPE> from the copyright screen to return to the command line interface.
Syntax	MEnu
Examples	mux [U]> menu
Related commands	None
Menu Equivalent	None

READ commands There is an equivalent **read** commands for every **set** command. The setting is displayed in the form of a command that will make that setting.

Syntax **REAd [text]**

text a **set** command with the **set** and the value to be set omitted

Groups of settings can be read by using a shortened form (see examples).

Examples mux [U]>**read power s**
set power s normal

mux [U]>**read power**
set power s normal
set power u sealing
set power bri on

Related commands **set** commands
help commands

Menu Equivalent All menus.

COMMAND LINE INTERFACE

RECALL command Recalls the alternate settings and stores them as the current settings.

Syntax **RECall**

Examples mux [S]> **recall**
Recall settings
Confirm Yes/No (Y/N)
y
Settings recalled

Related commands save

Menu Equivalent System Setup
 - Recall settings

RESET L1 BRI command	Resets layer 1 on a basic rate port ie deactivates interface, resets driver and interface and activates interface.
Syntax	RESEt L1 BRi [port]
	port Port number(s) from 1 (for BRI 1) to 16 (for BRI 16)
Examples	<pre>mux [S]> reset l1 bri 2 bri 2: layer 1 reset requested</pre>
Related commands	<pre>reset l1 pri reset l3 analogue reset l3 bri reset l3 pri</pre>
Menu Equivalent	None.

COMMAND LINE INTERFACE

RESET L1 PRI Resets layer 1 on a primary rate port ie resets driver and interface.
command

Syntax **RESEt L1 PRi [port]**

port Port number(s) from 1 (for PRI 1) to 2 (for PRI 2)

Examples mux [S]> **reset l1 pri 2**
pri 2: layer 1 reset requested

Related commands reset l1 bri
reset l3 analogue
reset l3 bri
reset l3 pri

Menu Equivalent None.

RESET L3 ANALOGUE Resets layer 3 on an analogue port ie clears the call.
command

Syntax **RESEt L3 Analogue [port]**

port Port number(s) from 1 (for A1) to 32 (for A32)

Examples mux [S]> **reset l3 analogue 2**
a2: layer 3 reset requested

Related commands reset l1 bri
reset l1 pri
reset l3 bri
reset l3 pri

Menu Equivalent None.

COMMAND LINE INTERFACE

RESET L3 BRI command	Resets layer 3 on a basic rate port ie clears all calls. Also frees SPID's when National ISDN protocol is selected.
Syntax	RESEt L3 BRi [port]
	port Port number(s) from 1 (for BRI 1) to 16 (for BRI 16)
Examples	mux [S]> reset l3 bri 2 bri 2: layer 3 reset requested
Related commands	reset l1 bri reset l1 pri reset l3 analogue reset l3 pri
Menu Equivalent	None.

RESET L3 PRI command	Resets layer 3 on a primary rate port ie clears all calls.
Syntax	RESEt L3 PRi [port]
	port Port number(s) from 1 (for PRI 1) to 2 (for PRI 2)
Examples	mux [S]> reset l3 pri 2 pri 2: layer 3 reset requested
Related commands	reset l1 bri reset l1 pri reset l3 analogue reset l3 bri
Menu Equivalent	None.

COMMAND LINE INTERFACE

RESTART BRI command	Sends a restart message to a basic rate port. This command can only be used for point to point ports. NB if any calls are active a reset 13 bri command should be used first.
Syntax	REStArt BRi [port] port Port number(s) from 1 (for BRI 1) to 16 (for BRI 16)
Examples	mux [S]> restart bri 1 bri 1: requesting restart message
Related commands	restart pri
Menu Equivalent	None.

RESTART PRI command	Sends a restart message to a primary rate port. NB if any calls are active a reset l3 pri command should be used first.
Syntax	REStArt PRi [port]
	port Port number(s) from 1 (for PRI 1) to 2 (for PRI 2)
Examples	mux [S]> restart pri 1 pri 1: requesting restart message
Related commands	restart bri
Menu Equivalent	None.

COMMAND LINE INTERFACE

SAVE command Saves the current settings as the alternate settings.

Syntax **SAve**

Examples mux [S]> **save**
Save settings
Confirm Yes/No (Y/N)
y
Settings saved

Related commands save

Menu Equivalent System Setup
- Save settings

SET ANALOGUE CLID Sets the format of the caller ID signal for analogue ports.
command

Syntax **SEt Analogue CLid [mode]**

mode **OFF** Caller ID disabled
ETSI FSK to ETSI standard
BELLCore FSK to Bellcore standard
DTMF DTMF

Examples mux [S]> **set analogue clid etsi**
OK

Related commands set analogue disconnect
set analogue impedance
set analogue ring
set analogue start

Menu Equivalent Hardware Setup
- Analogue Caller ID Mode

COMMAND LINE INTERFACE

**SET ANALOGUE
DISCONNECT
command** Sets the type of line change when a call is disconnected.

Syntax **SEt Analogue DISConnect [mode]**

mode OFF No change
BREak Line break
REVerse Line reversal

Examples mux [S]> **set analogue disconnect break**
OK

Related commands set analogue clid
set analogue impedance
set analogue ring
set analogue start

Menu Equivalent Hardware Setup
- Analogue Disconnect Mode

SET ANALOGUE IMPEDANCE command Sets the impedance set for analogue lines.

Syntax **SEt Analogue IMPedance [mode]**

mode **UK** UK impedance set
ETSI ETSI impedance set
USA USA impedance set
GERMANY German impedance set
600R 600 ohm impedance set

Examples mux [S]> **set analogue impedance uk**
OK

Related commands set analogue clid
set analogue disconnect
set analogue ring
set analogue start

Menu Equivalent Hardware Setup
- Analogue Impedance

COMMAND LINE INTERFACE

SET ANALOGUE RING command Sets the frequency and cadences used for ringing on analogue ports.

Syntax **SEt Analogue RIng [mode]**
or SEt Analogue RIng CUsTom [f] [c1] [c2] [c3]

mode **NORmal** Normal (UK style) ringing
USA USA style ringing

f **16** 16 Hz
20 20 Hz
25 25 Hz
50 50 Hz

c1 initial cadence
c2 cadence alternated with **c3**
c3 cadence alternated with **c2**

NB **c1**, **c2**, **c3** are in the form a/b where a is on time and b is off time, both in 50ms units. Maximum values are 150 for 7.5 seconds. Use 0/0 for cadences that are not required. A cadence with either the on time or the off time (but not both) set to zero is invalid.

Examples mux [S]> **set analogue ring normal**
OK
mux [S]> **set analogue ring custom 25 20/20 8/4 40/4**
OK

Related commands set analogue clid
set analogue disconnect
set analogue impedance
set analogue start

Menu Equivalent Hardware Setup
- Analogue Ring Mode

SET ANALOGUE START command Sets the analogue lines to use loop start or ground start.

Syntax **SEt Analogue STArT [mode]**

mode **NORmal** Normal (Loop start)
GROund Ground start

Examples mux [S]> **set analogue start normal**
OK

Related commands set analogue clid
set analogue disconnect
set analogue impedance
set analogue ring

Menu Equivalent Hardware Setup
- Analogue Start

COMMAND LINE INTERFACE

SET ANALYSER BRI Enables/disables analyser display for a basic rate port
command

Syntax **SEt ANALYser BRi [port] [mode]**

port Port number(s) from 1 (for BRI 1) to 16 (for BRI 16)

mode **OFF** display off
ON display on

Examples mux [S]> **set analyser bri 12 on**
OK

Related commands analyser
set analyser l1
set analyser l2
set analyser l3
set analyser pri
set analyser protocol
set analyser reference
trace

Menu Equivalent Analyser Setup
- Channel Filter

SET ANALYSER L1 Sets the analyser display mode for layer 1 (physical) of the ISDN trace.
command

Syntax **SEt ANALYser L1 [mode]**

mode **OFF** no display
 SHort short text display

Examples mux [S]> **set analyser l1 short**
 OK

Related commands analyser
 set analyser bri
 set analyser l2
 set analyser l3
 set analyser pri
 set analyser protocol
 set analyser reference
 trace

Menu Equivalent Analyser Setup
 - Layer 1 Hardware

COMMAND LINE INTERFACE

SET ANALYSER L2 Sets the analyser display mode for layer 2 (datalink) of the ISDN trace.
command

Syntax **SEt ANALYser L2 [mode]**

mode	OFF	no display
	HEX	hexadecimal display
	SHort	short text display
	LOnG	long text display

Examples mux [S]> **set analyser l2 short**
OK

Related commands analyser
set analyser bri
set analyser l1
set analyser l3
set analyser pri
set analyser protocol
set analyser reference
trace

Menu Equivalent Analyser Setup
- Layer 2 Data Link

SET ANALYSER L3 command Sets the analyser display mode for layer 3 (call control) of the ISDN trace.

Syntax **SEt ANALYser L3 [mode]**

mode	OFF	no display
	HEX	hexadecimal display
	SHort	short text display
	LOng	long text display

Examples mux [S]> **set analyser l3 short**
OK

Related commands analyser
set analyser bri
set analyser l1
set analyser l2
set analyser pri
set analyser protocol
set analyser reference
trace

Menu Equivalent Analyser Setup
- Layer 3 Call Control

COMMAND LINE INTERFACE

SET ANALYSER PRI Enables/disables analyser display for a primary rate port
command

Syntax **SEt ANALYser PRI [port] [mode]**

port Port number(s) from 1 (for PRI 1) to 2 (for PRI 2)

mode **OFF** display off
ON display on

Examples mux [S]> **set analyser pri 2 on**
OK

Related commands analyser
set analyser bri
set analyser l1
set analyser l2
set analyser l3
set analyser protocol
set analyser reference
trace

Menu Equivalent Analyser Setup
- Channel Filter

SET ANALYSER PROTOCOL command Sets the protocol assumed for the analyser trace.

Syntax **SEt ANALYser PRotocol [protocol]**

protocol	ETSI	ETSI protocol
	NAT1	Bellcore National ISDN protocol
	5ESS	AT&T 5ESS protocol
	DMS	NORTEL DMS100 protocol
	VN3	VN3 protocol
	BT	BTNR191 protocol
	1TR6	1TR6 protocol
	NTT	NTT protocol

Examples mux [S]> mux [S]> **set analyser protocol etsi**
OK

Related commands analyser
set analyser bri
set analyser l1
set analyser l2
set analyser l3
set analyser pri
set analyser protocol
trace

Menu Equivalent Analyser Setup
 - Analyser Specification

COMMAND LINE INTERFACE

**SET ANALYSER
REFERENCE command**

Sets the analyser call reference filter.

Syntax **SEt ANALYser REFerence [callref]**

callref A call reference (1 to 126 for BRI, 1 to 65534 for PRI)

If **callref** is omitted any existng call reference filter is deleted

Examples mux [S]> mux [S]> **set analyser reference 27**
OK

Related commands

analyser
set analyser bri
set analyser l1
set analyser l2
set analyser l3
set analyser pri
set analyser protocol
trace

Menu Equivalent

Analyser Setup
- Call Reference Filter

SET CHANNELS Sets the number of b channels that can be used for calls on an analogue port.
ANALOGUE command

Syntax **SEt CHannels Analogue [port] [channels]**

port Port number(s) from 1 (for A1) to 32 (for A32)

channels Maximum number of channels - 0 to 1

Examples mux [S]> **set channels analogue 11 1**
OK

Related commands set channels bri
set channels pri

Menu Equivalent Software Setup
- Channel Setup
- Analogue Ports

COMMAND LINE INTERFACE

SET CHANNELS BRI Sets the number of b channels that can be used for calls on a basic rate port.
command

Syntax **SEt CHannels BRi [port] [channels]**

port Port number(s) from 1 (for BRI 1) to 16 (for BRI 16)

channels Maximum number of channels - 0 to 2

Examples mux [S]> **set channels bri 14 2**
OK

Related commands set channels analogue
set channels pri

Menu Equivalent Software Setup
- Channel Setup
- Basic Rate Ports

SET CHANNELS PRI command	Sets the number of b channels that can be used for calls on a primary rate port.
Syntax	SEt CHannels PRi [port] [channels]
port	Port number(s) from 1 (for PRI 1) to 2 (for PRI 2)
channels	Maximum number of channels - 0 to 30 (for E1) / 23 (for T1)
Examples	mux [S]> set channels pri 1 30 OK
Related commands	set channels analogue set channels bri
Menu Equivalent	Software Setup <ul style="list-style-type: none">- Channel Setup- Primary Rate Ports

COMMAND LINE INTERFACE

**SET
COMMUNICATION
command**

Sets up the terminal port.

Syntax **SEt COMMunication [baudrate] [data] [parity] [stopbits]**

baudrate Baud rate in bits per second.
Allowed values are 4800, 9600, 19200, 38400, 57600 and 115200

data **7** 7 data bits
 8 8 data bits

parity **N** no parity
 E even parity
 O odd parity

stopbits **1** 1 stop bit
 2 2 stop bits

Examples mux [S]> **set communication 19200 8 N 1**
OK

Related commands set terminal

Menu Equivalent Hardware Setup

- Coms Port Baud Rate
- Coms Port Parity
- Coms Port Data Bits
- Coms Port Stop Bits.

SET CONNECTION Sets up or removes a semi-permanent connection.
PRI command

Syntax **SEt CONNecTion PRi [port1] [timeslot]**
 or SEt CONNecTion PRi [port1] [timeslot] [port2] [channel]
 or SEt CONNecTion PRi [port1] [timeslot] [port3] [timeslot]

port1 Port number(s) from 1 (for PRI 1) to 2 (for PRI 2)

port2 A port number from 1 (for BRI 1) to 16 (for BRI 16)

port3 Port number 2 (for PRI 2)

timeslot Timeslot number(s) between 0 and 31 (for E1)
 Timeslot number(s) between 1 and 24 (for T1)

channel A b channel number between 1 (for b1) and 2 (for b2)

If **port2/port3** and **channel/timeslot** are omitted then any existing connection is removed.

Examples mux [S]> **set connection pri 1 1 pri 2 1**
 OK
 mux [S]> **set connection pri 1 2 bri 15 1**
 OK
 mux [S]> **set connection pri 2 3 bri 15 2**
 OK

Related commands None

Menu Equivalent Software Setup
 - Connection Setup

COMMAND LINE INTERFACE

SET DATE command Sets the stored date.

Syntax **SEt DAtE [date]**

date date formatted as DD/MM/YY

Examples mux [S]>**set date 13:04:15**

Related commands None

Menu Equivalent System Setup
- System Time

COMMAND LINE INTERFACE

SET E1 command Sets up the framing, line code and international bit of the E1 primary rate ports.

Syntax **SEt E1 [linecode] [frame] [sibit]**

linecode	HDB3	HDB3 line code
	AMI	AMI line code
frame	BAsic	Basic framing
	CRC4	CRC-4 multiframing
sibit	1	Si (international) bits are 1
	FEBE	Si (international) bits are FEBE bits

If **frame** is **basic** then **sibit** must be **1**.

Examples mux [S]> **set e1 hdb3 crc4 1**
OK

Related commands set mode equaliser
set mode pri

Menu Equivalent Hardware Setup
- PRI E1 Mode

COMMAND LINE INTERFACE

SET IDLE Sets the number of minutes that the command line interface can be idle in supervisor mode before reverting to user mode.

Syntax **SEt IDLe** [**idle time**]

idle idle time in minutes (1-250)

If **idle** is omitted there is no limit.

Examples

```
mux [S]>set idle 20
OK
system_1 [S]> set idle
OK
mux [S]>
```

Related commands None

Menu Equivalent None

COMMAND LINE INTERFACE

SET IP command Sets the ip address configuration. If it is set to auto a BOOTP or DHCP server is needed on the network.

Syntax **SEt IP FIxed [IP address] [subnet mask] [gateway]**
SEt IP AUto

IP address IP address (must be unique)

Subnet mask subnet mask for the network or 0.0.0.0 if not known

Gateway IP address of gateway or 0.0.0.0 if no gateway

Examples mux [S]> **set ip fixed 192.168.0.40 255.255.255.0 0.0.0.0**
OK
mux [S]> **set ip auto**
OK

Related commands None

Menu Equivalent System Setup
- IP Setup

COMMAND LINE INTERFACE

SET LENGTH command Sets the number of lines that the command line interface will display before prompting the user to press a key.

Syntax **SEt LENgth [length]**

length display length (1-250)

If **length** is omitted there is no limit.

Examples

```
mux [S]>set length 20
OK
system_1 [S]> set length
OK
mux [S]>
```

Related commands None

Menu Equivalent None

SET MODE BRI Sets a BRI to be point-to-point (PP) or point-to-multipoint (PMP)
command

Syntax **SEt MODe BRi [port] [mode]**

port Port number(s) from 1 (for BRI 1) to 16 (for BRI 16)

mode **PP** Point-to-point
PMp Point-to-multipoint

Examples mux [S]> **set bri 1 pmp**
OK

Related commands None

Menu Equivalent Software Setup
- Datalink Setup

COMMAND LINE INTERFACE

SET MODE CLID command	Enables/disables Calling Party Number checking/generation.
Syntax	SEt MOde CLid [mode]
	mode ON Calling Party Number checking/generation enabled
	OFF Calling Party Number checking/generation disabled
Examples	mux [S]> set mode clid on OK
Related commands	set number pri set number bri set mode number set mode screening
Menu Equivalent	Software Setup - CLID Generation

COMMAND LINE INTERFACE

SET MODE NUMBER command	Sets the number type and plan in the calling party number when CLID generation is on. NB if it is set to national the numbers in number setup should be the national number (area code without prefix digit followed by local number) (only if CLID generation on)
Syntax	SEt MOde NUmber [mode]
	mode NORmal normal (unchanged if number passed, set to unknown type / unknown plan if number changed)
	NATIONAl always set to national type / ISDN/telephony plan
Examples	mux [S]> set mode number normal OK
Related commands	set number pri set number bri set mode clid set mode screening
Menu Equivalent	Software Setup - CLID Number Type

SET MODE PLAN command	Sets the number plan used to detect dialling completion. (National ISDN protocol only)
Syntax	SEt MOde PLaN [mode]
	mode NORmal Numbering plan unknown USa USA Numbering plan
Examples	mux [S]> set mode plan usa OK
Related commands	None
Menu Equivalent	Software Setup - Numbering plan

COMMAND LINE INTERFACE

SET MODE PRI command	Sets the primary rate ports to E1 or T1.
Syntax	SEt MODe PRI [mode]
	mode E1 2.048 Mbits/s (30B+D) T1 1.544 Mbits/s (23B+D)
Examples	mux [S]> set mode pri e1 OK
Related commands	set e1 set t1 set mode equaliser
Menu Equivalent	Hardware Setup - PRI E1/T1 Mode

SET MODE Sets the protocol used on all ISDN connections.
PROTOCOL command

Syntax **SEt MOde PROtocol [mode]**

mode **ETSI** ETSI EuroISDN
 NAT1 National ISDN

Examples mux [S]> **set mode protocol etsi**
 OK

Related commands None

Menu Equivalent Software Setup
 - Protocol

COMMAND LINE INTERFACE

SET MODE RESERVE Enables/disables b channel reservation on hold (National ISDN protocol only).
command

Syntax **SEt MOde RESERve [mode]**

mode **ON** Reserve a b channel when calls on hold
 OFF Don't reserve a b channel when calls on hold

Examples mux [S]> **set mode reserve on**
 OK

Related commands None

Menu Equivalent Software Setup
 - BRI HOLD Reserve Channel

SET MODE ROUTE Sets the routing mode for calls (ETSI protocol only).
command

Syntax **SEt MOde ROUte [mode]**

mode	NUmber	Number based routing
	CHannel	Channel based routing
	FIxed	Number based routing to specific channel

Examples mux [S]> **set mode route number**
OK

Related commands auto route
set route

Menu Equivalent Software Setup
- Routing Mode

COMMAND LINE INTERFACE

SET MODE SCREENING command Sets the screening indicator in the calling party number when CLID generation is on.
(only if CLID generation on)

Syntax **SEt MOde SCReening [mode]**

mode	NORmal	normal (unchanged if number passed, set to user-provided /not screened if number changed)
	NETwork	always set to network generated

Examples mux [S]> **set mode screening normal**
OK

Related commands set number pri
set number bri
set mode number
set mode clid

Menu Equivalent Software Setup
- CLID Screening Type

COMMAND LINE INTERFACE

SET MODE SPID command	Sets the acceptance/rejection of calls when terminal initialisation has not occurred (ie valid SPID not received) (National ISDN protocol only)
Syntax	SEt MOde SPid [mode]
	mode OPTional Calls permitted without terminal initialisation MANDatory Calls not permitted without terminal initialisation
Examples	mux [S]> set mode spid optional OK
Related commands	None
Menu Equivalent	Software Setup - BRI Require SPID

COMMAND LINE INTERFACE

SET MODE TONE command	Enables/disables local tone generation. (ETSI protocol only)
Syntax	SEt MOde TOne [mode]
	mode ON Use internal tones
	OFF Use network tones
	AUto Use internal or network tones depending on presence of progress indicator.
Examples	mux [S]> set tone on OK
Related commands	None
Menu Equivalent	Software Setup - Use Internal Tones

SET NAME command Sets the system name. The command prompt changes to reflect it.

Syntax **SEt NAmE [name]**

name name (up to 15 characters, no spaces allowed)

If **name** is omitted the system name is deleted and the default prompt is used.

Examples

```
mux [S]>set name system_1
OK
system_1 [S]> set name
OK
mux [S]>
```

Related commands None

Menu Equivalent System Setup
- System Name

COMMAND LINE INTERFACE

SET NUMBER BRI Sets up a telephone number for a basic rate port.
command

Syntax **SEt Number BRi [port] [x] [number]**

port Port number(s) from 1 (for BRI 1) to 16 (for BRI 16)

x Number(s) between 1 and 10 (ETSI protocol)
Number(s) between 1 and 2 (National ISDN protocol)

number telephone number (up to 15 digits)

If **number** is omitted any existing telephone number is deleted.
For National ISDN protocol the SPID is automatically changed to **number**+0101.

Examples mux [S]> **set number BRI 15 10 555123**
OK

Related commands set number PRI

Menu Equivalent Software Setup
- Number Setup
- Basic Rate Ports

SET NUMBER PRI Sets up a telephone number for a primary rate port.
command

Syntax **SEt NUmber PRi [port] [x] [number]**

port 2 (for PRI 2)

x 1

number telephone number (up to 15 digits)

If **number** is omitted any existing telephone number is deleted.

Examples mux [S]> **set number PRI 2 1 555123**
OK

Related commands set number BRI
set number PRI

Menu Equivalent Software Setup
- Number Setup
- Primary Rate Ports

COMMAND LINE INTERFACE

SET PASSWORD command	Sets the system password. This password is required to enter supervisor mode.
Syntax	SEt PAssword [pass] pass password (up to 15 characters, no spaces allowed) If pass is omitted the system password is deleted and no password is required to enter super mode.
Examples	<code>mux [S]>set password hello</code> OK
Related commands	None
Menu Equivalent	System Setup - System Password

SET POWER BRI command Enables/disables power feeding to basic rate ports (both s and u).

Syntax **SEt POWER Bri [mode]**

mode **ON** Power enabled
 OFF Power disabled

Examples mux [S]> **set power bri on**
 OK

Related commands set power restart
 set power s
 set power u

Menu Equivalent Hardware Setup
 - BRI S/U Power Feed

COMMAND LINE INTERFACE

SET POWER RESTART command Sets the mode for restoring power feeding on basic rate U interfaces. (after an overload with normal (50mA) current limit).

Syntax **SEt POWER REStArt [mode]**

mode	NORmal	Power restarted after 30 seconds
	OFF	Power not restarted

Examples mux [S]> **set power restart normal**
OK

Related commands set power bri
set power s
set power u

Menu Equivalent Hardware Setup
- BRI U Power Restart

SET POWER S command	Sets the power feeding mode on basic rate S interfaces. (Switches power polarity).
Syntax	SEt POWER S [mode]
	mode NORmal Normal mode power RESTRicted Restricted mode power
Examples	mux [S]> set power s normal OK
Related commands	set power bri set power restart set power u
Menu Equivalent	Hardware Setup - BRI S Power Mode

COMMAND LINE INTERFACE

SET POWER U command	Sets the power feeding mode on basic rate U interfaces. (Switches current limiter).
Syntax	SEt POWER U [mode]
	mode SEAling Sealing mode power (current limiter on)
	NORmal Normal mode power (current limiter off)
Examples	mux [S]> set power u sealing OK
Related commands	set power bri set power restart set power s
Menu Equivalent	Hardware Setup - BRI U Power Mode

COMMAND LINE INTERFACE

SET ROUTE PRI command Sets up or removes a route. (ETSI protocol only - also requires routing mode to be channel)

Syntax **SEt ROUte PRi [port1] [timeslot]**
or SEt ROUte PRi [port1] [timeslot] [port2] [channel]
or SEt ROUte PRi [port1] [timeslot] [port3] [timeslot]

port1 Port number 1 (for PRI 1)

port2 A port number from 1 (for BRI 1) to 16 (for BRI 16)

port3 Port number 2 (for PRI 2)

timeslot Timeslot number(s) between 0 and 31 (for E1)

Timeslot number(s) between 1 and 24 (for T1)

channel A b channel number between 1 (for b1) and 2 (for b2)

If **port2/port3/port4** and **channel/timeslot** are omitted then any existing route is removed.

Examples mux [S]> **set connection pri 1 1 pri 2 1**
OK
mux [S]> **set connection pri 1 2 bri 8 1**
OK

Related commands auto route
set mode route

Menu Equivalent Software Setup
- Routing Setup

COMMAND LINE INTERFACE

SET S command Sets the timing mode on the S interfaces.

Syntax **SEt S [mode]**

mode **FIxed** Fixed timing
 ADaptive Adaptive timing

Examples mux [S]> **set s fixed**
 OK

Related commands None

Menu Equivalent Hardware Setup
 - BRI S Bus Timing

SET TARGET command Sets the target IP addresses for SNMP traps. Up to 3 target IP addresses can be defined. An IP address of 0.0.0.0 is used to show no target defined. The IP address can also be omitted to set no target defined.

Syntax **SEt TARGeT [x] [IP address]**
SEt TARGeT [x]

X Number between 1 and 3

IP address IP address (must be unique)

Examples mux [S]> **set target 1 192.168.0.88**
OK
mux [S]> **set target 1**
OK

Related commands None

Menu Equivalent System Setup
 - IP Setup

COMMAND LINE INTERFACE

**SET TERMINAL
command** Sets up the terminal emulation to be matched.

Syntax **SEt TErminal [type]**

type	COLOUR	ANSI Colour
	ANSI	ANSI
	WYse	Wyse 50

Examples mux [S]> **set terminal colour**
OK

Related commands set communication

Menu Equivalent Hardware Setup
- Terminal type

SET T1 command Sets up the framing and line code of the T1 primary rate ports .

Syntax **SEt T1 [linecode] [frame]**

linecode **B8ZS** B8ZS line code

frame **ESF** ESF framing

Examples mux [S]> **set t1 b8zs esf**
OK

Related commands set mode pri
 set mode equaliser

Menu Equivalent Hardware Setup
 - PRI T1 Mode

COMMAND LINE INTERFACE

SET TIME command Sets the stored time.

Syntax **SEt Time [time]**

time time in 24 hour clock and format HH:MM:SS

Examples mux [S]>**set time 13:04:15**

Related commands None

Menu Equivalent System Setup
- System Time

START L1 BRI command	Starts layer 1 on a basic rate port ie activates it.
Syntax	STARt L1 BRi [port]
	port Port number(s) from 1 (for BRI 1) to 16 (for BRI 16)
Examples	mux [S]> start l1 bri 2 bri 2: layer 1 establishment requested
Related commands	start l2 bri start l2 pri
Menu Equivalent	None.

COMMAND LINE INTERFACE

START L2 BRI command	Starts layer 2 on a basic rate port ie starts the data link. NB only ports in point to point mode can have layer 2 started by this command.
Syntax	START L2 BRi [port]
	port Port number(s) from 1 (for BRI 1) to 16 (for BRI 16)
Examples	mux [S]> start l1 bri 2 bri 2: layer 2 establishment requested
Related commands	start l1 bri start l2 pri
Menu Equivalent	None.

START L2 PRI command	Starts layer 2 on a primary port ie starts the data link.
Syntax	STARt L2 PRi [port]
	port Port number(s) from 1 (for PRI 1) to 2 (for PRI 2)
Examples	mux [S]> start l1 pri 2 pri 2: layer 2 establishment requested
Related commands	start l1 bri start l2 bri
Menu Equivalent	None.

COMMAND LINE INTERFACE

STATUS command Displays the status of the system including all ports. It is equivalent to **status system, status analogue, status bri, and status pri.**

Syntax **STATus**

Examples mux [U]> **status**

Related commands status analogue
status bri
status pri
status system

Menu Equivalent None.

STATUS ANALOGUE Displays the status of analogue port(s).
command

Syntax **STATus Analogue [port]**

port Port number(s) from 1 (for A1) to 32 (for A32)

If **port** is omitted the status of all analogue ports is displayed.

Examples mux [U]>**status analogue 11**

```
all status:
  line : off hook
  number(1) : '14'
  number(2) : ''
  number(3) : ''
  number(4) : ''
  number(5) : ''
  clid generation:off
  local tones: off

all virtual BRI status :
  layer 2 point-multipoint : tei 64 sapi 0 multiple frame established
  layer 3 b: tei 64 #1 u->n (call setup) [pri 1 tei 0 #1 ts01(b1) ]
```

Related commands status
status bri
status pri
status system

Menu Equivalent None.

COMMAND LINE INTERFACE

STATUS BRI command Displays the status of basic rate port(s).

Syntax **STATus BRi [port]**

port Port number(s) from 1 (for BRI 1) to 16 (for BRI 16)

If **port** is omitted the status of all basic rate ports is displayed.

Examples mux [U]> **status bri 1**

```
bri 1 : S interface (fixed timing, normal power)
power on
layer 1 not active
layer 2 point-multipoint : no TEI's assigned
layer 3 b1: free
          b2: free
          number( 1) : '01'
          number( 2) : ''
          "
          number( 9) : ''
          number(10) : ''
          clid generation:off
          local tones: off
```

Related commands status
 status analogue
 status pri
 status system

Menu Equivalent None.

COMMAND LINE INTERFACE

STATUS PRI command Displays the status of primary rate port (s).

Syntax **STATus PRI [port]**

port Port number(s) from 1 (for PRI 1) to 2 (for PRI 2)

If **port** is omitted the status of all primary rate ports is displayed.

Examples mux [U]> **status pri 1**

```
pri 1 : E1 interface (hdb3 / crc4 / 1)
layer 1 active
layer 2 point-point : tei 0 sapi 0 multiple frame established
layer 3 ts00( f ) : framing channel
          ts01(b1) : tei 0 #1 u->n [bri 8 tei 0 #1 b1 (connected)]
                "
                "
          ts16( d ) : signalling channel
                "
                "
          ts31(b30) : free
```

Related commands status
status analogue
status bri
status system

Menu Equivalent None.

COMMAND LINE INTERFACE

STATUS SYSTEM	Displays system status.
command	
Syntax	STATus SYstem
Examples	<pre>mux [U]> status system system: hardware: dig19 (16U 2P [set to E1]) tone module: EPROM modem module: not fitted software: (development version) (flash)[boot sector: v2.0b] tcp/ip : fixed ip address : 192.168.0.130 subnet mask : 255.255.255.0 gateway : 0.0.0.0 snmp trap address 1 : 0.0.0.0 snmp trap address 2 : 0.0.0.0 snmp trap address 3 : 0.0.0.0 protocol: ETSI real time clock: detected access: user - read only name: (no name) password: (no password) time: 23/12/98 12:11:04 comms: 115200,8,N,2 (ansi terminal) calls: 0 active (0 on hold), 0 suspended (0 cleared)</pre>
Related commands	<pre>status status analogue status bri status pri</pre>
Menu Equivalent	None.

COMMAND LINE INTERFACE

SUPER command	Selects supervisor mode (read and write access). The user is prompted for a password if there is a password stored.
Syntax	SUPervisor
Examples	mux [U]> supervisor OK mux [S]>
Related commands	user set password
Menu Equivalent	System Setup - System Mode

COMMAND LINE INTERFACE

SWL command (Software Load)	Uploads new software to FLASH. More details are given in an appendix .
Syntax	SWL
Examples	mux [S]>swl
Related commands	None
Menu Equivalent	System Setup - Reprogram FLASH

SWL ANALOGUE command	Uploads new software to the analogue card. More details are given in an appendix .
Syntax	SWL Analogue
Examples	mux [S]>swl analogue
Related commands	None
Menu Equivalent	System Setup - Reprogram Analogue

COMMAND LINE INTERFACE

TEST BRI command Tests U interface line quality by sending a loopback command to the NT-1 and performing a 20 second bit error rate test.

Syntax **TESt BRi [port]**

port Port number(s) from 1 (for BRI 1) to 16 (for BRI 16)

Examples mux [S]> **test bri 2**
bert test bri 2:
activating.....
waiting for sync...
testing.....
1282828 bits,0 errors

Related commands None.

Menu Equivalent None.

COMMAND LINE INTERFACE

TRACE command Clears the protocol analyser and enables protocol analyser display.

Syntax **TRace**

Examples mux [U]> **trace**

```
3 : TA Ch BRI1 L3                                00:16:14:12.173
      PD= 8, LEN= 1, FLAG= Orig, CALL REF= 1 SETUP

4 : MUX Ch PRI1 L3                                00:16:14:12.217
      PD= 8, LEN= 2, FLAG= Orig, CALL REF= 4 SETUP

7 : NET Ch PRI1 L3                                00:16:14:12.285
      PD= 8, LEN= 2, FLAG= Dest, CALL REF= 4 SETUP ACKNOWLEDGE

9 : MUX Ch BRI1 L3                                00:16:14:12.316
      PD= 8, LEN= 1, FLAG= Dest, CALL REF= 1 SETUP ACKNOWLEDGE
```

Related commands

- set analyser l1
- set analyser l2
- set analyser l3
- set analyser bri
- set analyser pri
- set analyser reference
- set analyser protocol
- analyser

Menu Equivalent None

COMMAND LINE INTERFACE

UPLOAD command Lists all the commands that would create the current configuration. If the output is logged to a file a command file is created which can be sent to **arcaplex|Horizon** later to restore this configuration.

Some commands are preceded by a **rem** to prevent them being executed if a file generated in this way is used for configuration.

NB When using a PC to send a command file make sure that it is set for hardware flow control.

Syntax **UPlod**

Examples

```
mux [S]> upload
set analyser bri 1 off
set analyser bri 2 off
"
"
set terminal ansi
rem set time 12:15:42
```

Related commands None

Menu Equivalent None

USER command	Selects user mode (read only).
Syntax	USER
Examples	mux [S]> super OK mux [U]>
Related commands	supervisor set password
Menu Equivalent	System Setup - System Mode

COMMAND LINE INTERFACE

VERSION command Returns the current version number.

Syntax **VERsion**

Examples mux [U]> **version**
software: V1.3a 23 December 1998 (flash)[boot sector: v1.0a]

Related commands None

Menu Equivalent Version information is displayed on copyright screen.

FAULT FINDING

Introduction

This section seeks to provide some guidance on solving common problems encountered in using **arcaplex|Horizon**.

Changing a parameter on arcaplex|Horizon caused it to stop operating.

Changing parameters on **arcaplex|Horizon** may cause the unit to change operating modes and appear to stop functioning.

To recover from this condition reload the factory defaults (see Quick Reference Guide).

Windows terminal or telnet program will not move up and down menus.

When using the Windows terminal emulation program in its default configuration the <up> and <down> arrow keys will not function with the menus. This is because Windows uses these keys and does not pass any characters to **arcaplex|Horizon**.

In most cases <up> can be replaced with the 'u' or 'U' key and <down> by the 'd' or 'D' key.

Alternatively change the operation of the terminal program by disabling the "Use Function, Arrow and Ctrl Keys for Windows" option.

Set the terminal program to ANSI or VT100 to work with default (ANSI) terminal setting. You may also have to select an option like "VT100 arrows".

No communication with terminal port.

Communication failure can occur for several reasons. Firstly check that **arcaplex|Horizon** is powering up properly. The power LED should illuminate and the other LED's should turn on and off. The internal relays should usually switch on power up and this should be audible.

Next check the cable. **arcaplex|Horizon** provides a DCE connection so a cable with a 9 way D male to 9 way D female connected pin for pin will connect **arcaplex|Horizon** to a PC.

FAULT FINDING

If the cable is correct then check the communication parameters. The default is 19200 baud, no parity, 2 stop bits and 8 data bits.

To restore the default communication parameters reload the factory defaults (see Quick Reference Guide).

Changing parameters had no effect on operation of arcplex|Horizon.

Some parameters once changed will not effect the operation of the unit immediately. If **arcplex|Horizon** does not seem to be operating properly use the <esc> key to go back to the previous menu. If this does not work then switch **arcplex|Horizon** off and on again. Please inform **arcatech**.

Protocol Analyser will not run.

Check the analyser option i.e. at least one level of decode must be enabled and the interface to which the terminal is connected must be enabled. If you are not sure set decode for layers 1, 2 and 3 on all interface ports.

Network connection will not activate at layer 1 (i.e. P led does not illuminate)

Check that you have selected the correct primary rate mode for the PRI line.

Check *PRI E1/T1 mode* in *Hardware Setup* matches the PRI line.

E1 - Check *PRI E1 Mode* in *Hardware Setup* matches the line coding and framing standard on the PRI line. If this information is not known try HDB3/CRC-4/Si=1.

T1 - Check the network is compatible with **arcplex|Horizon**. It should be T1 (1.544 Mbit/s) with Extended Super Frame (ESF) and B8ZS line coding.

Terminal will not activate at layer 1 (i.e. P led does not illuminate)

If the P LED does not illuminate then the physical connection between the terminal, and **arcplex|Horizon** is not functioning. Check first that the terminal is connected to the correct interface type. The *Copyright Screen* displays the type of interface installed for each port.

CHAPTER 5

FAULT FINDING

If it is a BRI terminal try changing the power settings in *Hardware Setup*. Set *BRI S/U Power Feed* to *ON*. If it is an S interface BRI terminal try setting *BRI S Power Mode* to both *normal* and *restricted*.

For US originating products with U interfaces then *BRI U Power Mode* should be set to *Sealing*. To power NT-1's the U interface power should be set to *Normal*. Be careful when switching to U interface normal power as products intended to be connected to current limited U interface may be damaged by non current limited power (e.g. Motorola Bitsurfer).

For primary rate check that *PRI E1/T! Mode* in *Hardware Setup* matches the terminal.

For E1 equipment check that *PRI E1 Mode* in *Hardware Setup* matches the line coding and framing standard for the terminal. If this information is not known try *HDB3/CRC-4/Si=1*.

For T1 equipment check it is compatible with **arcaplex|Horizon**. **arcaplex|Horizon** supports Extended Super Frame (ESF) and B8ZS line coding.

Terminal will not make or answer a call.

If the P light stays off see the section on "Terminal will not activate at layer 1". If the P light flashes check that there are not too many terminals on the line. For basic rate the maximum is 8 (1 for point-to-point) and for primary rate the maximum is 1.

For a basic rate port check that the *BRI Setup* is correct in *Software Setup*. This should be *point to point* if it is a point-to-point terminal expecting TEI=0. Otherwise it should be *point to multipoint* which allows automatic TEI assignment.

If the P light fails to light the terminal may be faulty.

Now check that there are channels enabled on that port and that there are sufficient channels enabled on PRI 1 ie check *Channel*

FAULT FINDING

Setup is correct in *Software Setup*.

If ETSI protocol is set and *routing mode* is set to *channel* check that a route to PRI 1 has been set up.

Check that the terminal is compatible with the network. For example if using an ETSI network the terminals should be ETSI compliant. Other terminals may not function due to protocol errors.

For BRI TA's being used with National ISDN protocol check that the correct SPID has been entered in the TA. This should consist of the number for the TA (in *Number Setup*) + 0101. NB if *BRI Require SPID* in *Software Setup* is set to *No* **arcaplex|Horizon** will allow calls to be made without a correct SPID but the TA may block the call itself.

Use the protocol analyser to display the layer 3 messages. The called terminal may send DISCONNECT, RELEASE or RELEASE COMPLETE with a cause value indicating the problem.

A potential problem may be that called terminal and calling terminal do not support the same bearer capability in which case the called terminal will send RELEASE COMPLETE with a cause "Incompatible Destination". Another possibility is that the called terminal is expecting a Called Party Number or Calling Party Number information element in the SETUP message. These are optional services from the network.

Incoming calls are rejected or not routed correctly

If the B light on the called port switches on but the P light stays off see the section on "Terminal will not activate at layer 1".

For a basic rate port check that the *BRI Setup* is correct in *Software Setup*. This should be *point to point* if it is a point-to-

CHAPTER 5

FAULT FINDING

point terminal expecting TEI=0. Otherwise it should be *point to multipoint* which uses the global TEI (127).

Now check that there are channels enabled on that port and that there are sufficient channels enabled on PRI 1 ie check *Channel Setup* is correct in *Software Setup*

If ETSI protocol is set and *routing mode* is set to *channel* check that a route to PRI 1 has been set up.

Otherwise check that *Called Party Number* and *Number Setup* are compatible as follows...

Use the protocol analyser to check that the network is providing a *CalledParty Number* in the *SETUP* message and that a match number in *Number Setup* matches it.

For ETSI protocol a match requires the n digits of the match number for the port that the call is to be routed to match the last n digits of the *Called Party Number*.

For National ISDN protocol a match requires the match number for the BRI TA that the call is to be routed to match the *Called Party Number*. The n digits of the shorter number are compared to the last n digits of the longer number. This allows a match when an area code is not included in one of the numbers.

B channel not freed (B light stays on) when call is on hold

If ETSI protocol is set and routing mode is set to channel the b channel should not be freed. Otherwise....

When calls are placed on hold the B channel on PRI 1 is kept reserved. The b channel on the BRI for a call on hold is only freed if there is a spare channel on PRI 1. When the b channel is freed it is possible for the BRI to have more than 2 b channels on PRI 1 allocated to it. Hence to ensure that all enabled BRI's still have access to 2 b channels on PRI 1 the b channel for the call on hold on the BRI is only freed if there is a spare channel on PRI 1 or it is the first call on hold with b channel reserve on.

The number of spare channels is

(no. of channels enabled on PRI 1)

FAULT FINDING

- (no. of analogue channels enabled)
- (no. of BRI channels enabled)
- (no. of channels enabled on PRI 2)

APPENDICES

Reprogramming the FLASH

New software can be uploaded via the serial port, modem(optional) or the ethernet port. Telnet and FTP are used with the Ethernet port.

If the software is corrupted then upload has to be done via the serial port.

Initiating software upload From boot ROM

If the FLASH checksum is invalid **arcaplex|Horizon** will request reprogramming on power up.

If the FLASH is corrupted but still passes checksum **arcaplex|Horizon** can be forced to request reprogramming on power up. Set your terminal/PC to 19200 baud, 8 data bits, no parity and 2 stop bits. Switch **arcaplex|Horizon** on and press <ctrl-d> while the LED's are all on.

The following is displayed

```
ISDN Multiplexer BOOT 2.0b 26th October 1999
Ready to upload new firmware into FLASH.
Confirm Yes/No (Y/N)
```

NB if a debug prompt is displayed press <escape>.

If you wish to change to a higher baud rate it is possible to change over to 115200 baud by pressing <Escape> <9> <Return> .Set your PC/terminal to match and press <Escape>. The prompt will be re-displayed.

Press <Y> to proceed.

Initiating software upload from the menu system or command line interface

First of all you may wish to change to a higher baud rate in *hardware setup* or by using *set communication* and set your PC/terminal to match.

Select Reprogram FLASH in *system setup* and press <Enter> or type *swl* <ENTER> from the command line interface.

NB supervisor mode is required.

APPENDICES

The following is displayed if the serial port is being used.
Press <1> to proceed using serial port or <2> to proceed using
FTP.

```
Ready to upload new firmware into FLASH
Select download method
      (1)- serial port (2) - FTP (ESC) - abort
```

The following is displayed if the ethernet port is being used
(Telnet access). Press <Y> to proceed using FTP.

```
Ready to upload new firmware into FLASH (via FTP)
Confirm Yes/No (Y/N)
```

The following is displayed if the modem is being used Press <Y>
to proceed.

```
Ready to upload new firmware into FLASH
Confirm Yes/No (Y/N)
```

File transfer using serial port

If upload was initiated from the menu or command line the ISDN
protocol stack is stopped and the line cards are reset (all LED's on
the line cards will come on, relays may click on S cards).

The following is displayed

```
ISDN Multiplexer BOOT 2.0b 26th October 1999
Clearing RAM
Ready for S-RECORDs
```

Now send the file as raw ASCII. (or press <ESCAPE> to abort)
The LED's for PRI 1 will scroll during the download.

If the file is valid the following is displayed

```
S-RECORD download complete
initialise FLASH programming
FLASH erase
```

LED's will scroll for a few seconds then the following is

APPENDICES

displayed

FLASH program

LED's will scroll for a few more seconds then the following is displayed

FLASH program complete

If the file is not valid an error message will be displayed. The existing FLASH program will not have been changed.

If upload was initiated using the boot ROM then the following is displayed

Running debugger

Boot Debugger

>00C00164

Type <z> <Enter> to restart **arcaplex|Horizon**.

If upload was initiated using the command line or menu then **arcaplex|Horizon** will restart automatically if there were no errors otherwise press a key to make **arcaplex|Horizon** restart.

APPENDICES

File transfer using FTP

The ISDN protocol stack is stopped.

The following is displayed

```
Ready for s-records
  send via FTP to 192.168.0.40
  with user name 'arca', password 'technologies'
```

Now using an FTP program log in and send the file.

LED's on PRI 1 will scroll during the upload.

If the file is valid the following is displayed

```
valid s-record file received
DO NOT SWITCH OFF
  - system will reset when erase/program sequence is complete
```

If the upload was initiated using Telnet then the following is displayed.

```
telnet will disconnect - reconnection possible in 30 seconds
```

The line cards are reset (all LED's on the line cards will come on, relays may click on S cards).

LED's on PRI 1 will scroll during the erase/program sequence.

arcaplex|Horizon will then reset.

If the file is not valid an error message will be displayed. The existing FLASH program will not have been changed.

arcaplex|Horizon will reset automatically.

Log out or disconnect using the FTP program.

File transfer using modem

The ISDN protocol stack is stopped.

The following is displayed

```
Ready for s-records
```

Now send the file as raw ASCII. (or press <ESCAPE> to abort)

LED's on PRI 1 will scroll during the upload.

If the file is valid the following is displayed

APPENDICES

valid s-record file received

DO NOT SWITCH OFF

- system will reset when erase/program sequence is complete
modem will disconnect - reconnection possible in 30 seconds

The line cards are reset (all LED's on the line cards will come on,
relays may click on S cards).

LED's on PRI 1 will scroll during the erase/program sequence.
arcaplex|Horizon will then reset.

If the file is not valid an error message will be displayed. The
existing FLASH program will not have been changed.
arcaplex|Horizon will reset automatically.

APPENDICES

APPENDICES

Reprogramming an Analogue card

New software for the analogue card can be uploaded via the serial port, modem(optional) or the ethernet port. Telnet and FTP are used with the Ethernet port.

There are 2 pieces of software which can be loaded on to an analogue card

- 1 – card software
- 2 – DSP module software

Initiating software upload to analogue card

First of all you may wish to change to a higher baud rate in *hardware setup* or by using *set communication* and set your PC/terminal to match.

Select Reprogram Analogue in *system setup* and press <Enter> or type *swl analogue* <ENTER> from the command line interface. NB supervisor mode is required.

The following is displayed if the serial port is being used. Press <1> to proceed using serial port or <2> to proceed using FTP.

```
Ready to upload new firmware into analogue card
Select download method
      (1)- serial port (2) - FTP (ESC) - abort
```

The following is displayed if the ethernet port is being used (Telnet access).

```
Ready to upload new firmware into analogue card (via FTP)
```

The following is displayed if the modem is being used

```
Ready to upload new firmware into analogue card
```

APPENDICES

The following is displayed. Press <1> or <2> to select the line card to be reprogrammed.

```
Select line card
      (1) - Card 1 (2) - Card 2 (ESC) - abort
```

The following is displayed. Press <1> to reprogram the card software or <2> to reprogram the DSP module software.

```
Select card or DSP module
      (1) - card (2) - DSP
```

Reprogramming card software

If the software is to be uploaded via FTP the following is displayed

```
[card %d, current version %s]
Requesting analogue card to accept new program
Ready for s-records
send via FTP to 192.168.0.40
with user name 'arca', password 'technologies'
Now using an FTP program log in and send the file or press
<escape> to abort.
```

Otherwise the following is displayed

```
[card %d, current version %s]
Requesting analogue card to accept new program
Ready for s-records
Now send the file as raw ASCII or press <escape> to abort.
```

In both cases LED's on PRI 1 will scroll during the upload. When upload is complete the following is displayed

```
Transferring s-records
The LED's continue to scroll as the file is transferred to the
analogue card. When upload is successfully completed the
following is displayed
Download result: 'OK'
Waiting for analogue card to reprogram FLASH
```

- DO NOT SWITCH OFF

APPENDICES

[Programming takes around 30 seconds]

The LED's continue to scroll as the analogue card reprograms its FLASH with the new software.

The following should be displayed

Program result: 'OK'

If telnet is being used the following is displayed

telnet will disconnect - reconnection possible in 30 seconds

If the modem is being used the following is displayed

modem will disconnect - reconnection possible in 30 seconds

The line cards are reset (all LED's on the line cards will come on, relays may click on S cards).

arcaplex|Horizon will now reset.

If the file is not valid an error message will be displayed. The existing card software will not have been changed. **arcaplex|Horizon** will reset automatically.

If FTP is being used log out or disconnect using the FTP program.

APPENDICES

Reprogramming DSP module software

If the software is to be uploaded via FTP the following is displayed

```
[card %d, DSP version %s]
Ready for s-records
send via FTP to 192.168.0.40
with user name 'arca', password 'technologies'
```

Now using an FTP program log in and send the file or press <escape> to abort.

Otherwise the following is displayed

```
[card %d, DSP version %s]
Ready for s-records
```

Now send the file as raw ASCII or press <escape> to abort.

In both cases LED's on PRI 1 will scroll during the upload. When upload is complete the following is displayed

```
Requesting analogue card to accept new DSP program
Transferring s-records
```

The LED's continue to scroll as the file is transferred through the analogue card to the DSP module. When upload is successfully completed the following is displayed

```
Program result: 'OK'
Waiting for analogue card to reprogram DSP
```

- DO NOT SWITCH OFF

```
[Programming takes around 30 seconds]
```

The LED's continue to scroll as the analogue card reprograms the DSP module with the new software.

The following should be displayed

```
Program result: 'OK'
```

If telnet is being used the following is displayed

```
telnet will disconnect - reconnection possible in 30 seconds
```

If the modem is being used the following is displayed

```
modem will disconnect - reconnection possible in 30 seconds
```

APPENDICES

The line cards are reset (all LED's on the line cards will come on, relays may click on S cards).

arcaplex|Horizon will now reset.

If the file is not valid an error message will be displayed. The existing DSP module software will not have been changed. **arcaplex|Horizon** will reset automatically.

If FTP is being used log out or disconnect using the FTP program.

APPENDICES

Default Settings	This table shows the default settings for arcaplex Horizon . Some settings apply to only one protocol.
ETSI mode only settings	The following settings apply only to ETSI mode Routing Mode Routing Setup Use Internal Tones In National ISDN mode routing is always number based and internal tones are always used.
National ISDN mode only settings	The following settings apply only to National ISDN mode BRI Require SPID BRI HOLD reserve channel Numbering plan In ETSI mode channel reserve on hold is always enabled. The other settings are not relevant.
Numbers	Separate numbers are stored for ETSI and National ISDN protocols. Hence 2 sets of default numbers are listed.
SPID's	The SPID's (National ISDN protocol only) are fixed as the number in Number Setup with 0101 appended. e.g. BRI 12 has SPID's 3841120101 and 3841520101 if the default numbers are unchanged.

APPENDICES

	Parameter	Default Setting	
System Setup	System Name	no name	
	System Password	no password	
	IP settings	auto, no SNMP targets	
Hardware Setup	Coms Port Baud Rate	19200	
	Coms Port Parity	None	
	Coms Port Stop Bits	2	
	Coms Port Data Bits	8	
	Terminal type	ANSI	
	BRI S/U Power feeding	On	
	BRI S Power Mode	Normal	
	BRI U Power Mode	Sealing	
	BRI U Power Restart	Normal	
	BRI S bus timing	Fixed	
	PRI E1/T1 mode	E1	
	PRI Equaliser	Off	
	PRI E1 mode	HDB3/CRC-4/Si=FEBE	
	PRI T1 mode	B8ZS/ESF	
	Analogue Ring Mode	Normal	
	Analogue ID Mode	Off	
	Analogue Disc Mode	Line Break	
	Analogue Impedance	UK	
	Analogue Start	Normal	
	Software Setup	Protocol	ETSI EuroISDN
Routing Mode		Number	
Datalink Setup		all point-multipoint	
Channel Setup		PRI 1	30
		PRI 2	0
		BRI's	2
Connection Setup		all unallocated	
Number Setup		See next table	
Routing Setup		all unallocated	
CLID Generation		No	
Use Internal Tones	No		

APPENDICES

Analyser Setup	Layer 1 Hardware	Inactive
	Layer 2 Data Link	Inactive
	Layer 3 Call Control	ASCII long display
	Channel filter	all disabled
	Call reference filter	Inactive
	Analyser Specification	ETSI

APPENDICES

Number Setup for ETSI mode	BRI 1	or A1, A2	01, 51
	BRI 2	or A3, A4	02, 52
	BRI 3	or A5, A6	03, 53
	BRI 4	or A7, A8	04, 54
	BRI 5	or A9, A10	05, 55
	BRI 6	or A11, A12	06, 56
	BRI 7	or A13, A14	07, 57
	BRI 8	or A15, A16	08, 58
	BRI 9	or A17, A18	09, 59
	BRI 10	or A19, A20	10, 60
	BRI 11	or A21, A22	11, 61
	BRI 12	or A23, A24	12, 62
	BRI 13	or A25, A26	13, 63
	BRI 14	or A27, A28	14, 64
	BRI 15	or A29, A30	15, 65
	BRI 16	or A31, A32	16, 66
		PRI 2	99
Number Setup for National ISDN mode	BRI 1	or A1, A2	384101, 384151
	BRI 2	or A3, A4	384102, 384152
	BRI 3	or A5, A6	384103, 384153
	BRI 4	or A7, A8	384104, 384154
	BRI 5	or A9, A10	384105, 384155
	BRI 6	or A11, A12	384106, 384156
	BRI 7	or A13, A14	384107, 384157
	BRI 8	or A15, A16	384108, 384158
	BRI 9	or A17, A18	384109, 384159
	BRI 10	or A19, A20	384110, 384160
	BRI 11	or A21, A22	384111, 384161
	BRI 12	or A23, A24	384112, 384162
	BRI 13	or A25, A26	384113, 384163
	BRI 14	or A27, A28	384114, 384164
	BRI 15	or A29, A30	384115, 384165
	BRI 16	or A31, A32	384116, 384166
		PRI 2	384199

APPENDICES

ISDN interface Pin-outs

The following table shows the pin-outs of the RJ45 connectors for the ISDN interfaces.

	PRI 1	PRI 2	BRI	
	E1 or T1	E1 or T1	S	U
1	R-	T-	NC	NC
2	R+	T+	NC	NC
3	NC	NC	R-	NC
4	T-	R-	T-	RING
5	T+	R+	T+	TIP
6	NC	NC	R+	NC
7	NC	NC	NC	NC
8	NC	NC	NC	NC

Analogue Pin-out

The following table shows the pin-out of the RJ11 connector for the analogue (PSTN) interfaces.

	RJ11 connector
1	NC
2	NC
3	TIP
4	RING
5	NC
6	NC

APPENDICES

Ethernet interface Pin-out

The following table shows the pin-out of the RJ45 connector for the ethernet interface.

	RJ45 connector
1	T+
2	T-
3	R+
4	NC
5	NC
6	R-
7	NC
8	NC

Modem Pin-out

The following table shows the pin-out of the RJ11 connector for the modem (optional).

	RJ11 connector
1	NC
2	NC
3	TIP
4	RING
5	NC
6	NC

APPENDICES

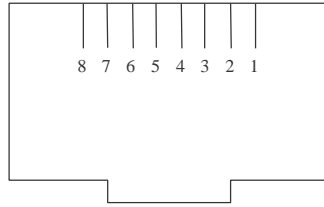

Figure 12 RJ45 plug (front view)

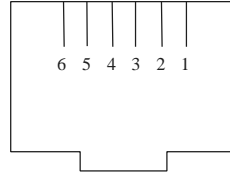

Figure 13 RJ11 plug (front view)

APPENDICES

Terminal port pin-out

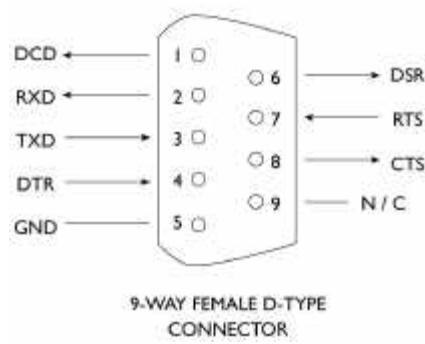

Figure 14 V.24 Terminal Port

Pin	Function	Description
1	DCD	Data Carrier Detect (always active)
2	RXD	Received Data (output)
3	TXD	Transmitted Data (input)
4	DTR	Data Terminal Ready (input- ignored)
5	GND	Ground
6	DSR	Data Set Ready (always active)
7	RTS	Request to Send (input- active to allow arcaplex Horizon to send Data)
8	CTS	Clear to Send (output- active when arcaplex Horizon can receive Data)

APPENDICES

BRI Power Feeding

Figure 15 shows a schematic of how the power is supplied at the ISDN S₀ interface port while figure 16 shows a schematic of U interface power feeding.

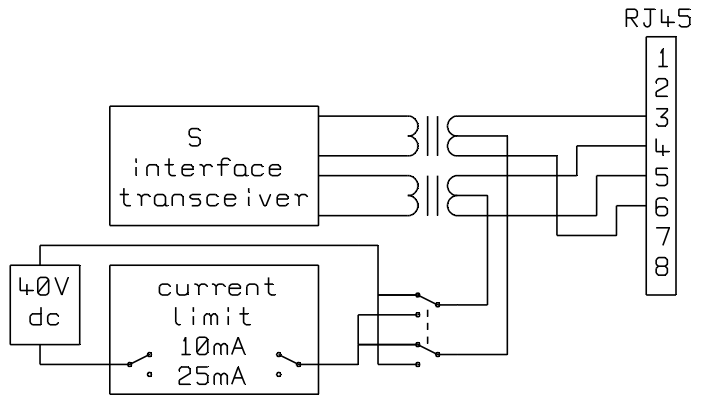

Figure 15 Schematic of 40 V Power Supply (S interface)

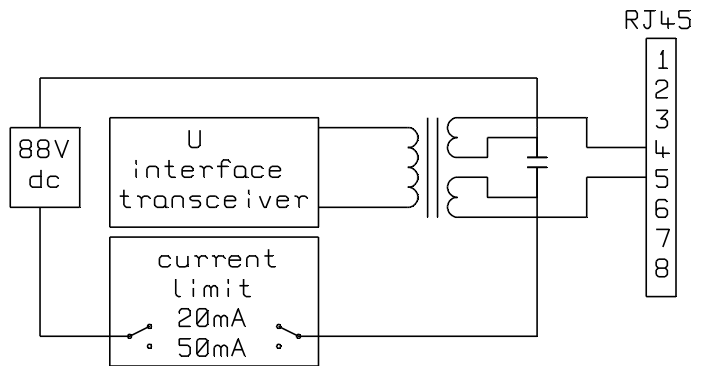

Figure 16 Schematic of 88V Power Supply (U interface)

APPENDICES

APPENDICES

Examples of Number Setup (ETSI protocol)

This appendix gives some example settings for Number Setup when ETSI protocol is selected and describes how incoming calls are routed (if Routing Mode is set to Number) and how the calling party number/subaddress on outgoing calls is effected (if CLID generation is on) in each case.

The examples for the telephone numbers are given as 7 digits ie just the local number. Telephone numbers with area code e.g. 04445551234 could be used but if the network doesn't include the area code in the Called Party Number then incoming calls would not be routed correctly. Shorter numbers could also be used, e.g. if all the numbers on the PRI are the same apart from the last 2 digits then a 2 digit number (like the default numbers) would be sufficient to route correctly.

When setting up the numbers it is important to delete any existing numbers that are no longer required.

For simplicity the following text assumes that the same format of numbers is used for each interface.

Reject all incoming calls

Delete all numbers in Number Setup.
Set PRI 2 to have 0 channels in Channel Setup
CLID generation (for outgoing calls) is not appropriate in this case.

Route all incoming calls to PRI 2

Delete all numbers in Number Setup.
Set PRI 2 to have some channels in Channel Setup
CLID generation (for outgoing calls) is not appropriate in this case.

Calls will be routed to PRI 2 if there is a free b channel.

Route to first interface with a free

Store * or ? for first number for each interface that is to receive

APPENDICES

channel incoming calls.
CLID generation (for outgoing calls) is not appropriate in this case.

Incoming calls with any Called Party Number will be accepted by the first port with a free b channel (any Called Party Subaddress is ignored).

Route by telephone number Store telephone number(s) (e.g. 5551234) for each interface that is to receive incoming calls.

If CLID generation is on use the first number for an interface to hold the telephone number to be used when a Calling Party Number is to be changed on or added to an outgoing call.

10 different telephone numbers can be assigned to the same interface.

The same number can be used for several interfaces to form a multi-line hunt group.

For the example of 5551234

Incoming calls with Called Party Number ending 5551234 will be accepted if there is a free b channel (any Called Party Subaddress is ignored).

Outgoing calls (with CLID generation on) will have their Calling Party Number checked (any Calling Party Subaddress is ignored).

Outgoing calls with Calling Party Number of 5551234 will have their Calling Party Number unchanged. Otherwise if none of the numbers for that port match then the Calling Party Number (and Subaddress) will be changed to the first number (and Subaddress) stored for that port.

APPENDICES

Route by subaddress

Store '?'# followed by a subaddress (e.g. ?#23) for each interface that is to receive incoming calls.

NB 10 different subaddresses can be assigned to the same interface.

CLID generation (for outgoing calls) is not appropriate with this format.

For the example of ?#23

Incoming calls with any Called Party Number and with a subaddress of 23 will be accepted if there is a free b channel.

Route by telephone number and subaddress

Store a telephone number followed by '#' followed by a subaddress (e.g. 5551234#44) for each interface that is to receive incoming calls. NB 10 different telephone numbers and subaddresses can be assigned to the same interface.

If CLID generation is on use the first number for an interface to hold the telephone number and subaddress to be used when Calling Party Number and Calling Party Subaddress are to be changed on or added to an outgoing call.

For the example of 5551234#44

Incoming calls with Called Party Number ending 5551234 and with a subaddress of 44 will be accepted.

Outgoing calls (with CLID generation on) will have their Calling Party Number and Calling Party Subaddress checked.

Outgoing calls with Calling Party Number of 5551234 and Calling Party Subaddress of 44 will have their Calling Party Number and Calling Party Subaddress unchanged. Otherwise if none of the numbers for that port match then the Calling Party Number (and Subaddress) will be changed to the first number (and Subaddress) stored for that port.

APPENDICES

Route based on telephone number with last digit as wildcard

Store a telephone number with a '?' in place of the last digit (e.g. 555123?) for each interface that is to receive incoming calls.

Store it as the first number if CLID generation is on and it is the preferred choice for when a Calling Party Number is to be changed on or added to an outgoing call. NB the '?' is changed to 0 if it is used as the Calling Party Number.

This is a useful way of allocating 10 numbers (for MSN) to a basic rate interface.

For the example of 555123?

Incoming calls with Called Party Number ending 5551230 to 5551239 will be accepted if there is a free b channel (any Called Party Subaddress is ignored) .

Outgoing calls (with CLID generation on) will have their Calling Party Number checked (any Calling Party Subaddress is ignored).

Outgoing calls with Calling Party Number of 5551230 to 5551239 will have their Calling Party Number unchanged. Otherwise if none of the numbers for that port match then the Calling Party Number (and Subaddress) will be changed to the first number (and Subaddress) stored for that port.

APPENDICES

**Route based on telephone number
allowing for extension number
(* option)**

Store a telephone number with a '*' after the last digit (e.g. 5551234*) for each interface that is to receive incoming calls.

Store it as the first number if CLID generation is on and it is the preferred choice for when a Calling Party Number is to be changed on or added to an outgoing call.

For the example of 5551234*

Incoming calls with Called Party Number containing 5551234 will be accepted (any Called Party Subaddress is ignored).

Outgoing calls (with CLID generation on) will have their Calling Party Number checked (any Calling Party Subaddress is ignored).

Outgoing calls with Calling Party Number starting with 5551234 will have their Calling Party Number unchanged. Otherwise if none of the numbers for that port match then the Calling Party Number (and Subaddress) will be changed to the first number (and Subaddress) stored for that port. If the received Calling Party Number is 5 digits or less it is assumed to be an extension number and will be appended to the new Calling Party Number.

**Route based on telephone number
allowing for extension number
(+ option)**

Store a telephone number with a '+' after the last digit (e.g. 5551234+) for each interface that is to receive incoming calls.

Store it as the first number if CLID generation is on and it is the preferred choice for when a Calling Party Number is to be changed on or added to an outgoing call.

For the example of 5551234+

Incoming calls with Called Party Number containing 5551234 will be accepted (any Called Party Subaddress is ignored). The 5551234 and any preceding digits will not be passed through to the called interface. This is so that only the extension number is passed through.

APPENDICES

Outgoing calls (with CLID generation on) will have their Calling Party Number checked (any Calling Party Subaddress is ignored).

Outgoing calls with Calling Party Number starting with 5551234 will have their Calling Party Number unchanged.

Otherwise if none of the numbers for that port match then the Calling Party Number (and Subaddress) will be changed to the first number (and Subaddress) stored for that port. If the received Calling Party Number is 5 digits or less it is assumed to be an extension number and will be appended to the new Calling Party Number.

APPENDICES

Examples of Number Setup (National ISDN protocol)

This appendix gives some example settings for Number Setup when National ISDN protocol is selected and describes how incoming calls are routed and (if CLID generation is on) how the calling party number on outgoing calls is effected in each case.

The examples for the telephone numbers are given as 7 digits ie just the local number. Telephone numbers with area code e.g. 4445551234 could also be used.

When setting up the numbers it is important to delete any existing numbers that are no longer required.

For simplicity the following text assumes that the same format of numbers is used for each interface.

Subaddressing is not supported when National ISDN protocol is selected.

Reject all incoming calls

Delete all numbers in Number Setup.
Set PRI 2 to have 0 channels in Channel Setup
CLID generation (for outgoing calls) is not appropriate in this case.

Program the SPID's of BRI equipment as 0101 if the BRI equipment needs a SPID to make outgoing calls.

Route all incoming calls to PRI 2

Delete all numbers in Number Setup.
Set PRI 2 to have some channels in Channel Setup
CLID generation (for outgoing calls) is not appropriate in this case.

Program the SPID's of BRI equipment as 0101 if the BRI equipment needs a SPID to make outgoing calls.

APPENDICES

Calls will be routed to PRI 2 if there is a free b channel.

Route by telephone number

Store 1 or 2 telephone number(s) (e.g. 5551234) for each basic rate interface that is to receive incoming calls.

Program the SPID's of BRI equipment as *telephone number+0101* if the BRI equipment needs a SPID to make outgoing calls or accept incoming calls. This also allows calls to be routed to a specific TA.

For the example of 5551234

Incoming calls with Called Party Number ending 5551234 will be accepted if there is a free b channel.

Outgoing calls (with CLID generation on) will have their Calling Party Number checked.

Outgoing calls with Calling Party Number ending 5551234 will have their Calling Party Number unchanged. If the endpoint identifier (linked to the SPID) is not included then Calling Party Number will be unchanged if it matches the other number for that interface. Otherwise the Calling Party Number will be changed. The new Calling Party Number will be the number associated with the endpoint identifier (linked to the SPID) if the endpoint identifier is included. If the endpoint identifier is not included then the first number for that interface will be used.

When used for a basic rate interface the SPID associated with the telephone number 5551234 is 55512340101.

APPENDICES

SNMP support **arcaplex|Horizon** supports SNMP to allow remote monitoring. SNMP is used via the Ethernet port. It should be accessed using a PC running SNMP software. It is necessary to add the **arca** MIB file to the programs MIB Database and compile it to access the custom SNMP status and correctly display the custom trap. The MIB file is available from **arcatech**.

Polling An SNMP program can be used to poll **arcaplex|Horizon** and display if it is not responding e.g. if power cut off.

Traps A “cold start” trap is generated when **arcaplex|Horizon** powers up or is reset. NB “warm start” trap is not supported.

A custom trap is generated when a PRI port becomes inactive (at layer 1).

Traps are sent to the targets defined in *System Setup* or by the *set target* command. They can be disabled by setting the targets to 0.0.0.0. The targets should be running an SNMP program to accept the traps and display them and/or notify a designated person.

Traps will not be sent if **arcaplex|Horizon** is set to get an IP address automatically and no IP address has been received. The cold start trap may not be sent with automatic IP addressing.

Standard SNMP status **arcaplex|Horizon** supports the standard MIB 2 features such as *system description*. These items can be found in the “mgmt” group when using a MIB Browser.

Custom SNMP status **arcaplex|Horizon** supports status monitoring of the ISDN and analogue ports. The serial number can also be accessed.

For basic rate ports the following can be monitored

- layer 1 (active / inactive)

APPENDICES

- layer 2 (TEI values and datalink status)
- b channels (free / call / connection / disabled)
- power feeding status (off / on / limiting)
- power feeding mode (off / normal / restricted [S]/ sealing[U])
- interface type (S / U / not fitted)

For primary rate ports the following can be monitored

- layer 1 (active / inactive)
- layer 2 (TEI values and datalink status)
- b channels (free / call / connection / disabled)

For analogue ports the following can be monitored

- channel (free / call / disabled)
- fitted / not fitted

All these items can be found in the “arca” group (part of the “private” group) when using a MIB Browser.

GLOSSARY

AMI	Alternate Mark Inversion
B8ZS	Binary 8 Zeros Suppression
BOOTP	Bootstrap Protocol
BRI	Basic Rate Interface
CLID	Calling Line Identification
CRC-4	Cyclic Redundancy Check -4
DDI	Direct Dialling In
DHCP	Dynamic Host Configuration Protocol
ESF	Extended Super Frame
ETSI	European Telecommunications Standards Institute
FSK	Frequency Shift Keying
FTP	File Transfer Protocol
HDB3	High Density Bipolar 3
IP	Internet Protocol
ISDN	Integrated Services Digital Network
MIB	Management Information Base
MSN	Multiple Subscriber Numbering
PRI	Primary Rate Interface
PSTN	Public Switched Telephone Network
REN	Ring Equivalent Number
SNMP	Simple Network Management Protocol
SPID	Service Profile Identifier
TA	Terminal Adapter
TEI	Terminal Equipment Identifier
S	4 wire point-to-multipoint BRI line (can also be used as point-to-point)
U	2 wire point-to-point BRI line
E1	2.048 Mbit/s PRI line with up to 30 b channels as used in most countries
T1	1.544 Mbit/s PRI line up to 23 b channels as used in the USA and some other countries